

A modern industrial-style living room. The walls are made of large, light-colored panels. A white sofa is on the left, and a dark grey ottoman is on the right. A tall, narrow bookshelf is next to a window. A semi-transparent white box with text is overlaid on the left side of the image.

# INDUSTRIAL

Architectural design

# MADE IN FLORIM

## La ricerca della bellezza fa parte del patrimonio genetico dell'essere umano

In Florim questo istinto per la creatività si fonde con la passione e incontra la più moderna tecnologia produttiva per dar vita ad un nuovo tipo di prodotto. Un progetto morale non solo bello ma anche a basso impatto ambientale e pensato per far star bene le persone nel loro spazio. Abbiamo una lunga storia da raccontare e una gran voglia di guardare avanti in un futuro fatto di **bellezza, innovazione e sostenibilità**.

## *The pursuit of beauty is part of the human genetic heritage*

*At Florim, this instinct for creativity merges with passion and meets the most advanced production technology to create a new kind of product. A moral project that is not only beautiful but also environmentally friendly, designed to enhance well-being in personal spaces with a low environmental impact. We have a long story to tell and a strong desire to look forward to a future built on **beauty, innovation, and sustainability**.*

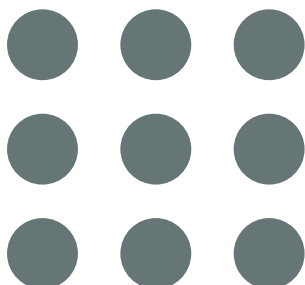

# ALTAGAMMA

## La bellezza e lo stile italiani nel mondo

Vocazione estetica, heritage culturale e forte identità sono alcuni degli elementi condivisi da Florim e Altagamma, la Fondazione che dal 1992 riunisce le **imprese ambasciatrici dello stile italiano nel mondo**. Una comunione di vedute che ha permesso a Florim di essere accolta nel 2022 come nuovo membro. La Fondazione racchiude l'élite delle aziende italiane votate all'**alto di gamma**: il segmento di mercato in costante crescita in tutto il mondo e nel quale il Made in Italy gioca un ruolo da protagonista. Altagamma riunisce i marchi più prestigiosi nei settori moda, design, gioielleria, alimentare, ospitalità, motori e nautica.

## *Italian beauty and style around the world*

*Aesthetic vocation, cultural heritage, and a strong identity are key elements shared by Florim and Altagamma, the foundation that since 1992 has brought together **companies that represent Italian style worldwide**. This shared vision led to Florim's induction as a new member in 2022. The Foundation includes the elite of Italian companies dedicated to the **high-end segment** - a market that continues to grow globally, where Made in Italy plays a leading role. Altagamma brings together the most prestigious brands in fashion, design, jewelry, food, hospitality, automotive, and yachting.*



# I cinque elementi della nostra sostenibilità

## Acqua, aria, terra e fuoco

Consideriamo i quattro elementi naturali come risorse uniche e preziose perché dal loro equilibrio dipende la sopravvivenza degli ecosistemi.

Il nostro compito è quello di proteggerli attraverso azioni quotidiane che, sommate, fanno la differenza.

**Ci piace pensare alla persona come "quinto elemento"**, tassello determinante per cambiare lo stato di crisi del nostro pianeta attraverso gesti consapevoli e scelte responsabili. In Florim, le nostre persone sono ambasciatrici di un modo di fare attento e consapevole. Sono il nostro DNA, rappresentano una cultura aziendale fondata sul rispetto e la valorizzazione, che si estende a tutte le persone del territorio.

Un impegno verso le persone e l'ambiente che Florim ha preso molto seriamente, è scritto nel nostro statuto.

Certified



Corporation

Siamo **Società Benefit** e certificati **B Corp** dal 2020.

## ACQUA / *water*



**100%**  
riciclo delle acque  
reflue di produzione  
*100% recycling  
of greenware waste*

In Florim **tutte le acque reflue del ciclo produttivo sono riutilizzate al 100%**. Nei nostri stabilimenti sono presenti delle **vasche di raccolta dell'acqua piovana** che recuperano l'acqua proveniente dalle precipitazioni. Per ottimizzare l'utilizzo delle risorse idriche abbiamo introdotto delle innovative **linee di squadratura a secco** che eliminano l'acqua utilizzata per la rettifica del materiale.

*At Florim, **all wastewater from the production cycle is 100% reused.** Our facilities are equipped with **rainwater collection tanks** that capture water from precipitation. To optimize water resource usage, we have introduced innovative **dry squaring lines** that eliminate the need for water in the material rectification process.*

## ARIA / *air*



**100%**  
autoproduzione dell'energia  
elettrica necessaria  
*100% self-production of the  
required electrical energy*

Ci stiamo impegnando a ridurre al massimo le emissioni generate dal nostro processo e dal nostro prodotto. Possiamo contare su **127.000 mq di superfici ricoperte da impianti fotovoltaici** in grado di generare una potenza di picco di 12,3 MWp e due impianti di cogenerazione che ci permettono di autoprodurre fino al 100% dell'energia elettrica necessaria alle sedi italiane. Quando la luce del sole non basta, **acquistiamo energia elettrica** proveniente **esclusivamente da fonti rinnovabili certificate**.

*We are committed to minimizing emissions generated by our processes and products. We have **127,000 square meters of surfaces covered with photovoltaic** systems capable of generating a peak power of 12.3 MWp, along with two cogeneration plants that allow us to self-produce up to 100% of the electricity needed for our Italian facilities. When sunlight is not enough, **we purchase electricity exclusively from certified renewable sources.***



# The five elements of our sustainability

## Water, air, earth, and fire

**We conceive the four natural elements as unique and precious resources because the survival of ecosystems depends on their balance.**

*Our role is to protect them through daily actions that, when combined, make a difference.*

**We like to think of people as the "fifth element",** a crucial piece in changing the current crisis of our planet through conscious actions and responsible choices. At Florim, our people are ambassadors of a mindful and attentive way of working. They are our DNA, embodying a corporate culture rooted in respect and appreciation, extending to everyone in our community.

*This commitment to people and the environment is one that Florim takes very seriously—it's written into our bylaws.*

*We are a **Benefit Corporation** and have been certified as a **B Corp** since 2020.*

## TERRA / earth



**100%**

**riciclo degli scarti crudi di produzione**  
*100% recycling of raw production waste*

Il nostro prodotto accoglie **oltre il 90% di materie prime di origine naturale** di altissima qualità. Ricicliamo il 100% degli scarti crudi di produzione e monitoriamo attentamente la catena di fornitura delle materie prime. I prodotti Florim accolgono **fino al 60% di materie prime riciclate**, la percentuale varia in base agli spessori e alle collezioni.

*Our products are made with **over 90% high-quality natural raw materials**. We recycle 100% of raw production waste and closely monitor our raw material supply chain. Florim products **contain up to 60% recycled raw materials**, with the percentage varying depending on thickness and collections.*

## FUOCO / fire



**100%**

**processo certificato ISO 9001 per la qualità, 50001 per l'energia, 14001 per l'ambiente**

*Our process is 100% certified: ISO 9001 for quality, ISO 50001 for energy management, and ISO 14001 for environmental management*

Il fuoco è l'elemento che cambia la materia e rende il prodotto ceramico **resistente** all'umidità, all'usura, agli agenti chimici e atmosferici. Il nostro gres viene cotto a circa 1200 gradi, questo lo rende un **materiale che dura nel tempo, sicuro e igienico**. Una qualità testimoniata da **numerose certificazioni di prodotto e processo**.

*Fire is the element that transforms matter, making ceramic products **resistant** to moisture, wear, and chemical and atmospheric agents. Our porcelain stoneware is fired at around 1200 degrees, **making it a durable, safe, and hygienic material**. This quality is backed by **numerous product and process certifications**.*

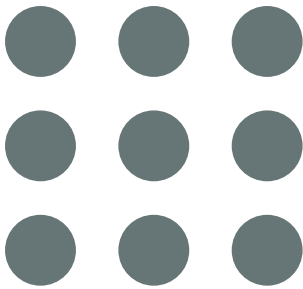

# CARBONZERO

## Le superfici Carbon Neutral di Florim

In linea con la nostra strategia che sposa un **paradigma di business a beneficio del pianeta**, dal 2023 promuoviamo CarbonZero: il progetto di superfici Carbon Neutral che compensano le emissioni di CO<sub>2</sub> generate dalla loro produzione e dal loro ciclo di vita.

### *Florim's Carbon Neutral surfaces*

*Aligned with our strategy of embracing a **business paradigm that benefits the planet**, in 2023 we launched CarbonZero: an initiative dedicated to Carbon Neutral surfaces that fully offset the CO<sub>2</sub> emissions produced throughout their manufacturing and lifecycle.*



**Scopri di più:**  
Find out more:



## Misuriamo

Abbiamo calcolato l'impatto ambientale delle nostre superfici **lungo il ciclo di vita del prodotto\*** perché vogliamo ridurre tutte le emissioni di CO<sub>2</sub>, anche quelle che avvengono al di fuori dell'azienda.

## We measure

*We have calculated the environmental impact of our surfaces **along the product life cycle** (\*) because we aim to reduce all CO<sub>2</sub> emissions, including those that occur outside.*

## Riduciamo

Per contenere le emissioni della nostra attività, **abbiamo ridotto l'uso di risorse naturali** e investito per rendere il processo produttivo **più sostenibile**: fino al 100% in termini di acqua, energia elettrica e recupero degli scarti crudi.

## We reduce

*To contain the emissions from our activity, **we have reduced the use of natural resources** and invested in making the production process **more sustainable**: up to 100% in terms of water, electricity, and raw waste recovery.*

## Compensiamo

**Promuoviamo un impatto positivo**: le collezioni CarbonZero **compensano tutta la CO<sub>2</sub> emessa durante il loro ciclo di vita**, supportando progetti certificati che producono energia pulita nei paesi in via di sviluppo. Il progetto CarbonZero unisce alla consueta bellezza e al design dei prodotti Florim l'impatto positivo dato dalla compensazione di CO<sub>2</sub>\*\*.

## We offset

***We promote a positive impact**: CarbonZero collections **offset all the CO<sub>2</sub> emitted during their life cycle**, supporting certified projects that produce clean energy in developing countries. The CarbonZero project combines beauty and design with the positive impact given by CO<sub>2</sub> offsetting (\*\*).*

(\*) dato certificato EPD – numero di registrazione EPDITALY0462

(\*\*) la compensazione avviene attraverso l'acquisto di crediti di carbonio CER (Certified Emission Reductions) sul registro CDM (Clean Development Mechanism) dell'UNFCCC (United Nations Framework for Climate Change). per il calcolo è stato utilizzato il valore di 19,05 kg di CO<sub>2</sub>-eq / m<sup>2</sup> con densità media di 21,97 kg/m<sup>2</sup> – dato calcolato partendo dal valore di GWP total (EPD Florim che considera l'intero ciclo di vita del prodotto) integrando le attività di manutenzione e pulizia ipotizzando una durata di 60 anni. Florim si impegna annualmente nel monitoraggio, riduzione e compensazione delle emissioni di gas ad effetto serra delle collezioni CarbonZero.

(\*) EPD certified data – registration number EPDITALY0462

(\*\*) Offsetting is achieved through the purchase of CER (Certified Emission Reductions) carbon credits on the CDM (Clean Development Mechanism) registry of the UNFCCC (United Nations Framework for Climate Change). For the calculation, a value of 19.05 kg of CO<sub>2</sub>-eq / m<sup>2</sup> with an average density of 21.97 kg/m<sup>2</sup> was used – this data was calculated starting from the total GWP value (EPD Florim that considers the entire life cycle of the product) integrating maintenance and cleaning activities assuming a lifespan of 60 years. Florim commits annually to monitoring, reducing, and offsetting the greenhouse gas emissions of the CarbonZero Collections.



# Architectural design

Materiale tecnico seguendo le tendenze dell'architettura, per applicazioni quali pavimentazioni industriali e realizzazioni pubbliche a medio e ad alto traffico, come aeroporti, centri commerciali, ristoranti, uffici, negozi, ma anche applicazioni residenziali con un mirato contenuto estetico.

Technical material in line with architectural trends, for applications such as industrial flooring and public buildings with medium to high footfall, such as airports, shopping centres, restaurants, offices, shops, as well as residential applications featuring a targeted aesthetic content.

Matériau technique suivant les tendances de l'architecture, pour des applications en tant que sols industriels et des réalisations publiques à trafic moyen et intense, comme les aéroports, les centres commerciaux, les restaurants, les bureaux, les magasins, mais aussi pour des applications résidentielles au contenu esthétique ciblé.

Technisches Material im Einklang mit den architektonischen Trends für Anwendungen wie Industrieböden und mittelhoch bis stark frequentierte öffentliche Bereiche wie Flughäfen, Einkaufszentren, Restaurants, Büros und Läden, aber auch für Wohngebäude mit wertiger Optik.

Material técnico que sigue las tendencias de la arquitectura, creado para pavimentos industriales y ambientes públicos de mediano y alto tránsito —como aeropuertos, centros comerciales, restaurantes, oficinas y tiendas—, pero también para aplicaciones residenciales con un refinado contenido estético.

performance



appeal





l

project



ecobuilding



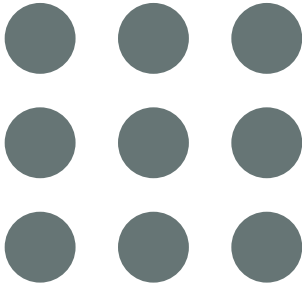

# INDUSTRIAL



**Architectural design**

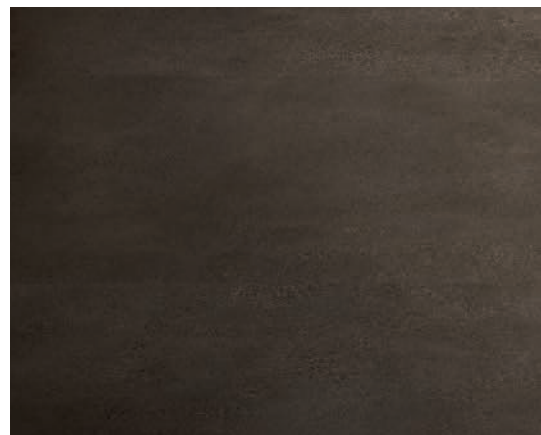



# INDUSTRIAL





Modernità e semplicità caratterizzano questa superficie neutra e lineare che si esprime attraverso un mix di colori, formati e decori. **Industrial** si propone nella sua forma pura, per essere utilizzata in modo trasversale, efficace e accattivante in ogni progetto di architettura. L'innovativo formato 120x240 permette di concepire lo spazio con una visione inedita che mostra chiaramente la sua matrice ispirativa.



# INDUSTRIAL

This neutral and linear surface is distinguished for being modern and simple, expressing itself through a mix of colours, sizes and decorations. **Industrial** presents itself in its purest form, to be used across the board, efficiently and captivatingly, in every architectural project. The innovative 120x240 size allows spaces to be conceived with a brand new vision that clearly displays its matrix of inspiration.

Modernité et simplicité caractérisent cette surface neutre et linéaire qui s'exprime dans un mélange de coloris, de formats et de décors. Efficace et captivante dans tous les projets d'architecture, **Industrial** se propose dans sa forme pure pour être utilisée de façon transversale. Son format innovateur 120x240 permet de concevoir l'espace avec une vision inédite qui démontre clairement son modèle d'inspiration.



Modernität und Einfachheit kennzeichnen diese neutrale und lineare Oberfläche, die sich durch einen Mix aus Farben, Formaten und Dekoren ausdrückt. **Industrial** bietet sich in seiner puren Form an, um übergreifend, effizient und ansprechend in jedem Architekturprojekt verwendet werden zu können. Das innovative Format 120x240 ermöglicht es, den Raum mit einer neuartigen Vision zu konzipieren, die deutlich ihren inspirierenden Ursprung zeigt.

Esta superficie neutra y lineal, que se expresa a través de una mezcla de colores, formatos y decoraciones, se caracteriza por su gran modernidad y simplicidad. **Industrial** se propone en su forma pura, para ser usada transversalmente, eficaz y fascinante en cualquier proyecto de arquitectura. El innovador formato 120x240 permite concebir el espacio con una visión inédita, que muestra claramente su matriz inspiradora.

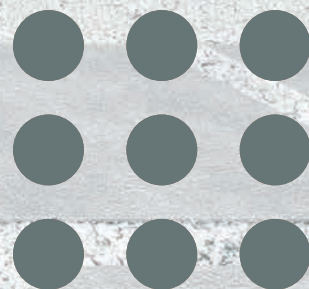

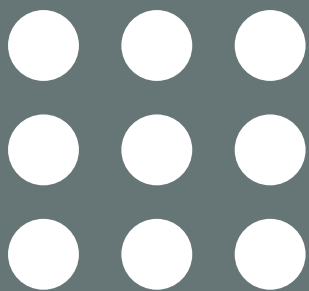

wall: ivory 120x240 47<sup>1/4</sup>"x94<sup>1/2</sup>" . decoro a+b ivory/taupe 30x30 11<sup>3/4</sup>"x11<sup>3/4</sup>"  
floor: moka matre 120x240 47<sup>1/4</sup>"x94<sup>1/2</sup>"







wall: ivory 120x240 47<sup>1/4</sup>"x94<sup>1/2</sup>" , decoro a+b ivory/taupe 30x30 11<sup>3/4</sup>"x11<sup>3/4</sup>"  
floor: moka matte 120x240 47<sup>1/4</sup>"x94<sup>1/2</sup>"





wall: ivory 120x240 47<sup>1/4"</sup>x94<sup>1/2"</sup> . decoro a+b ivory/taupe 30x30 11<sup>3/4"</sup>x11<sup>3/4"</sup>  
floor: moka matte 120x240 47<sup>1/4"</sup>x94<sup>1/2"</sup>





wall: ivory 120x240 47<sup>1/4</sup>"x94<sup>1/2</sup>"

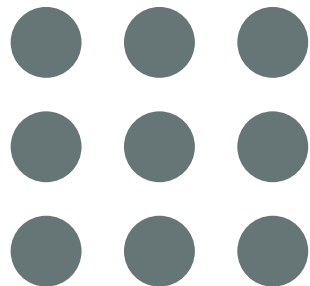



wall: ivory 120x240 47<sup>1/4</sup>"x94<sup>1/2</sup>" . deco a+b ivory/taupe 30x30 11<sup>3/4</sup>"x11<sup>3/4</sup>"  
floor: moka matte 120x240 47<sup>1/4</sup>"x94<sup>1/2</sup>"







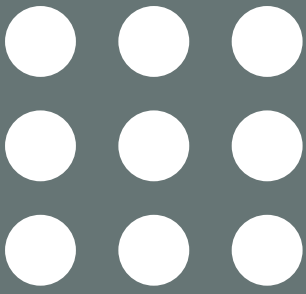

wall: decoro a+b ivory/taupe 30x30 11<sup>3/4</sup>"x11<sup>3/4</sup>"





wall: ivory 120x240 47<sup>1/4</sup>"x94<sup>1/2</sup>" . decoro a+b ivory/taupe 30x30 11<sup>3/4</sup>"x11<sup>3/4</sup>" . puzzle decor ivory 160x160 63"x63"  
floor: moka matte 120x240 47<sup>1/4</sup>"x94<sup>1/2</sup>"





wall: ivory 120x240 47<sup>1/4</sup>"x94<sup>1/2</sup>" . puzzle decor ivory 160x160 63"x63"  
floor: moka matte 120x240 47<sup>1/4</sup>"x94<sup>1/2</sup>"

















floor: steel soft 60x60 23<sup>5/8</sup>"x23<sup>5/8</sup>"

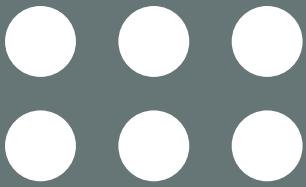

floor: sage soft 80x80 31<sup>1</sup>/<sub>2</sub>"x31<sup>1</sup>/<sub>2</sub>"





floor: sage soft 80x80 31<sup>1</sup>/<sub>2</sub>"x31<sup>1</sup>/<sub>2</sub>"







wall: listello sfalsato mix 3d ivory-moka-taupe soft 15x60 6"x23<sup>5/8"</sup>  
floor: plomb 30x60 11<sup>3/4"</sup>x23<sup>5/8"</sup>

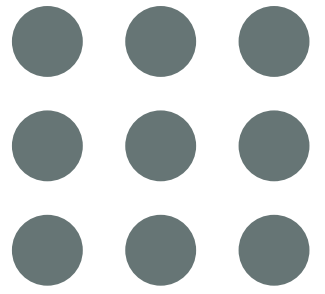





wall: listello sfalsato mix 3d ivory-moka-taupe soft 15x60 6"x23<sup>5/8"</sup>  
floor: plomb 30x60 11<sup>3/4"</sup>x23<sup>5/8"</sup>, plomb gradino 33x120 13"x47<sup>1/4"</sup>



wall: decoro B plomb/steel 30x30 11<sup>3/4</sup>"x11<sup>3/4</sup>"  
floor: plomb











wall: puzzle decor steel 160x160 63"x63"  
floor: steel 80x80 31 1/2"x31 1/2"





wall: plomb mosaico 30x30 31<sup>1</sup>/<sub>2</sub>"x31<sup>1</sup>/<sub>2</sub>"  
floor: plomb 60x120 23<sup>5</sup>/<sub>8</sub>"x47<sup>1</sup>/<sub>4</sub>"







wall: plomb mosaico 30x30 31<sup>1/2</sup>"x31<sup>1/2</sup>"  
floor: plomb 60x120 23<sup>5/8</sup>"x47<sup>1/4</sup>"







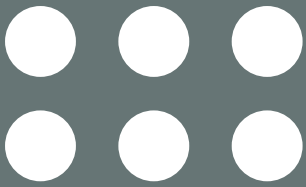

floor: taupe 2cm 60x60 23<sup>5/8</sup>"x23<sup>5/8</sup>" . taupe bocciardato 30x60 11<sup>3/4</sup>"x23<sup>5/8</sup>"





floor: taupe bocciardato 30x60 11<sup>3/4</sup>"x23<sup>5/8</sup>"



IVORY

**GRES FINE PORCELLANATO**

FINE PORCELAIN STONEWARE / GRÈS CÉRAME FIN / FEINSTEINZEUG-KOLLEKTIONEN / GRES PORCELÁNICO FINO  
 SQUADRATO - SQUARED - EQUARRI - REKTIFIZIERT - ESCUADRADO

9 mm 3/8" ↑↓	COLOR	SURFACE	60x120 23 <sup>5/8</sup> "x47 <sup>1/4</sup> "	80x80 31 <sup>1/2</sup> "x31 <sup>1/2</sup> "	60x60 23 <sup>5/8</sup> "x23 <sup>5/8</sup> "	30x60 11 <sup>4/5</sup> "x23 <sup>5/8</sup> "
<b>INDUSTRIAL</b>	IVORY	NATURALE/MATTE	738816	738656	738803	738791
		SOFT	738822	738662	738810	738797
		BOCCIARDATO BUSH-HAMMERED	-	-	-	738955

6 mm 1/4" ↑↓	FLOHM OVERSIZE	COLOR	SURFACE	160x320 63"x126"	160x160 63"x63"	120x280 47 <sup>1/4</sup> "x110 <sup>1/4</sup> "	120x240 47 <sup>1/4</sup> "x94 <sup>1/2</sup> "	120x120 47 <sup>1/4</sup> "x47 <sup>1/4</sup> "	80x80 31 <sup>1/2</sup> "x31 <sup>1/2</sup> "	60x120 23 <sup>5/8</sup> "x47 <sup>1/4</sup> "
<b>INDUSTRIAL</b>	magnum	IVORY	NATURALE/MATTE	744351	744393	757774	744399	744405	744381	744411
			R+PTV	-	-	-	758799	757780	-	-

## TAUPE

### GRES FINE PORCELLANATO

FINE PORCELAIN STONEWARE / GRÈS CÉRAME FIN / FEINSTEINZEUG-KOLLEKTIONEN / GRES PORCELÁNICO FINO  
 SQUADRATO - SQUARED - EQUARRI - REKTIFIZIERT - ESCUADRADO

9 mm 3/8" ↑↓		COLOR	SURFACE	60x120 23 <sup>5/8"</sup> x47 <sup>1/4"</sup>	80x80 31 <sup>1/2"</sup> x31 <sup>1/2"</sup>	60x60 23 <sup>5/8"</sup> x23 <sup>5/8"</sup>	30x60 11 <sup>4/8"</sup> x23 <sup>5/8"</sup>
INDUSTRIAL		TAUPE	NATURALE/MATTE	738819	738659	738807	738794
			SOFT	738825	738665	738813	738800
			BOCCIARDATO BUSH-HAMMERED	-	-	-	738958

6 mm 1/4" ↑↓		FLOPIM OVERSIZE magnum	COLOR	SURFACE	160x320 63"x126"	160x160 63"x63"	120x280 47 <sup>1/4"</sup> x110 <sup>1/4"</sup>	120x240 47 <sup>1/4"</sup> x94 <sup>1/2"</sup>	120x120 47 <sup>1/4"</sup> x47 <sup>1/4"</sup>	80x80 31 <sup>1/2"</sup> x31 <sup>1/2"</sup>	60x120 23 <sup>5/8"</sup> x47 <sup>1/4"</sup>
INDUSTRIAL		TAUPE	NATURALE/MATTE	744352	744394	757775	744400	744406	744382	744412	
			R+PTV	-	-	-	758800	757781	-	-	

MOKA

**GRES FINE PORCELLANATO**

FINE PORCELAIN STONEWARE / GRÈS CÉRAMÉ FIN / FEINSTEINZEUG-KOLLEKTIONEN / GRES PORCELÁNICO FINO  
 SQUADRATO - SQUARED - EQUARRI - REKTIFIZIERT - ESCUADRADO

9 mm 3/8" ↑↓	COLOR	SURFACE	60x120 23 <sup>5/8"</sup> x47 <sup>1/4"</sup>	80x80 31 <sup>1/2"</sup> x31 <sup>1/2"</sup>	60x60 23 <sup>5/8"</sup> x23 <sup>5/8"</sup>	30x60 11 <sup>4/5"</sup> x23 <sup>5/8"</sup>
INDUSTRIAL	MOKA	NATURALE/MATTE	738820	738660	738808	738795
		SOFT	738826	738666	738814	738801
		BOCCIARDATO BUSH-HAMMERED	-	-	-	738959

6 mm 1/4" ↑↓	FLOHM OVERSIZE magnUm	COLOR	SURFACE	160x320 63"x126"	160x160 63"x63"	120x280 47 <sup>1/4"</sup> x110 <sup>1/4"</sup>	120x240 47 <sup>1/4"</sup> x94 <sup>1/2"</sup>	120x120 47 <sup>1/4"</sup> x47 <sup>1/4"</sup>	80x80 31 <sup>1/2"</sup> x31 <sup>1/2"</sup>	60x120 23 <sup>5/8"</sup> x47 <sup>1/4"</sup>
INDUSTRIAL	MOKA	NATURALE/MATTE	744354	744396	757776	744402	744408	744384	744414	
		R+PTV	-	-	-	758801	757782	-	-	





# INDUSTRIAL

## SAGE

### GRES FINE PORCELLANATO

FINE PORCELAIN STONEWARE / GRÈS CÉRAMÉ FIN / FEINSTEINZEUG-KOLLEKTIONEN / GRES PORCELÁNICO FINO  
 SQUADRATO - SQUARED - EQUARRI - REKTIFIZIERT - ESCUADRADO

9 mm 3/8" ↑↓		COLOR	SURFACE	60x120 23 <sup>5/8"</sup> x47 <sup>1/4"</sup>	80x80 31 <sup>1/2"</sup> x31 <sup>1/2"</sup>	60x60 23 <sup>5/8"</sup> x23 <sup>5/8"</sup>	30x60 11 <sup>4/5"</sup> x23 <sup>5/8"</sup>
INDUSTRIAL		SAGE	NATURALE/MATTE	738817	738657	738804	738792
			SOFT	738823	738663	738811	738798
			BOCCIARDATO BUSH-HAMMERED	-	-	-	738956

6 mm 1/4" ↑↓		FLOHM OVERSIZE magnum	COLOR	SURFACE	160x320 63"x126"	160x160 63"x63"	120x280 47 <sup>1/4"</sup> x110 <sup>1/4"</sup>	120x240 47 <sup>1/4"</sup> x94 <sup>1/2"</sup>	120x120 47 <sup>1/4"</sup> x47 <sup>1/4"</sup>	80x80 31 <sup>1/2"</sup> x31 <sup>1/2"</sup>	60x120 23 <sup>5/8"</sup> x47 <sup>1/4"</sup>
INDUSTRIAL		SAGE	NATURALE/MATTE	744353	744395	757777	744401	744407	744383	744413	
			R+PTV	-	-	-	758802	757783	-	-	

STEEL

**GRES FINE PORCELLANATO**

FINE PORCELAIN STONEWARE / GRÈS CÉRAME FIN / FEINSTEINZEUG-KOLLEKTIONEN / GRES PORCELÁNICO FINO  
 SQUADRATO - SQUARED - EQUARRI - REKTIFIZIERT - ESCUADRADO

9 mm 3/8" ↑↓		COLOR	SURFACE	60x120 23 <sup>5/8"</sup> x47 <sup>1/4"</sup>	80x80 31 <sup>1/2"</sup> x31 <sup>1/2"</sup>	60x60 23 <sup>5/8"</sup> x23 <sup>5/8"</sup>	30x60 11 <sup>4/5"</sup> x23 <sup>5/8"</sup>
INDUSTRIAL		STEEL	NATURALE/MATTE	738818	738658	738806	738793
			SOFT	738824	738664	738812	738799
			BOCCIARDATO BUSH-HAMMERED	-	-	-	738957

6 mm 1/4" ↑↓		FLOHM OVERSIZE magnum	COLOR	SURFACE	160x320 63"x126"	160x160 63"x63"	120x280 47 <sup>1/4"</sup> x110 <sup>1/4"</sup>	120x240 47 <sup>1/4"</sup> x94 <sup>1/2"</sup>	120x120 47 <sup>1/4"</sup> x47 <sup>1/4"</sup>	80x80 31 <sup>1/2"</sup> x31 <sup>1/2"</sup>	60x120 23 <sup>5/8"</sup> x47 <sup>1/4"</sup>
INDUSTRIAL		STEEL	NATURALE/MATTE	744350	744392	757778	744398	744404	744380	744410	
			R+PTV	-	-	-	758803	757784	-	-	

# INDUSTRIAL

## PLOMB

### GRES FINE PORCELLANATO

FINE PORCELAIN STONEWARE / GRÈS CÉRAMÉ FIN / FEINSTEINZEUG-KOLLEKTIONEN / GRES PORCELÁNICO FINO  
 SQUADRATO - SQUARED - EQUARRI - REKTIFIZIERT - ESCUADRADO

9 mm $\frac{3}{8}$ "	COLOR	SURFACE	60x120 $23\frac{5}{8}$ "x47 $\frac{1}{4}$ "	80x80 $31\frac{1}{2}$ "x31 $\frac{1}{2}$ "	60x60 $23\frac{5}{8}$ "x23 $\frac{5}{8}$ "	30x60 $11\frac{4}{5}$ "x23 $\frac{5}{8}$ "
INDUSTRIAL	PLOMB	NATURALE/MATTE	738821	738661	738809	738796
		SOFT	738827	738667	738815	738802
		BOCCIARDATO BUSH-HAMMERED	-	-	-	738960

6 mm $\frac{1}{4}$ "	FLORM OVERSIZE magnum	COLOR	SURFACE	160x320 $63$ "x126"	160x160 $63$ "x63"	120x280 $47\frac{1}{4}$ "x110 $\frac{1}{4}$ "	120x240 $47\frac{1}{4}$ "x94 $\frac{1}{2}$ "	120x120 $47\frac{1}{4}$ "x47 $\frac{1}{4}$ "	80x80 $31\frac{1}{2}$ "x31 $\frac{1}{2}$ "	60x120 $23\frac{5}{8}$ "x47 $\frac{1}{4}$ "
INDUSTRIAL	PLOMB	NATURALE/MATTE		744355	744397	757779	744403	744409	744385	744415
		R+PTV		-	-	-	758804	757785	-	-

**GRES FINE PORCELLANATO**FINE PORCELAIN STONEWARE / GRÈS CÉRAME FIN / FEINSTEINZEUG-KOLLEKTIONEN / GRES PORCELÁNICO FINO  
SQUADRATO - SQUARED - EQUARRI - REKTIFIZIERT - ESCUADRADO**9 mm** 3/8" 

COLOR

SURFACE

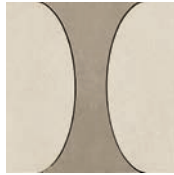
**30x30**  
11 4/5" x 11 4/5"DECORO A  
TAUPE / IVORY

SOFT

739434

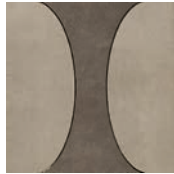
DECORO A  
MOKA / TAUPE

SOFT

739436

DECORO A  
PLOMB / STEEL

SOFT

739437

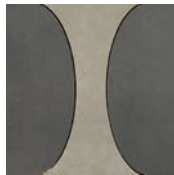
DECORO A  
SAGE / PLOMB

SOFT

739435

**INDUSTRIAL**DECORO B  
TAUPE / IVORY

SOFT

739438

DECORO B  
MOKA / TAUPE

SOFT

739440

DECORO B  
PLOMB / STEEL

SOFT

739441

DECORO B  
SAGE / PLOMB

SOFT

739439

## PUZZLE DECOR

La fuga diventa decoro, la separazione della materia acquista una nuova espressività grazie alla tecnologia dell'idrogetto. Ogni realizzazione può essere unica e personalizzata in base allo spazio in cui dovrà essere inserita, il decoro può essere adattato a qualsiasi misura richiesta. Fuga tra i pezzi 1 mm. Per la realizzazione del progetto serve la pianta del cliente con indicazione precisa delle misure delle pareti da rivestire. Nel caso in cui non ci siano pareti perfettamente in squadra i pezzi ai lati saranno lasciati più lunghi di 5 cm.

Joint spaces become part of the decoration. The space that separates the material acquires a new level of expression thanks to water-jet technology. Each project can be unique and customised based on the area where it will be installed. The decoration can be adapted to any requested measurements. 1 mm joint space between tiles. The customer's floor plan is required to design the project, providing the precise measurements of the walls where the material will be applied. If the walls are not perfectly square, the side pieces must be left 5 cm longer.

Le joint devient une décoration, la séparation de la matière acquiert une nouvelle expressivité grâce à la technologie de l'hydrojet. Toutes les réalisations peuvent être uniques et personnalisées selon l'espace où elles devront être insérées, la décoration peut être adaptée à toute mesure demandée. Joint entre les pièces 1 mm. Pour la réalisation du projet, il faut le plan du client avec l'indication précise des mesures des murs à couvrir. Au cas où les murs ne seraient pas parfaitement en équerre, les pièces sur les côtés seront laissées plus longues de 5 cm.

Die Fuge wird zum Dekor; die Trennung der Materie erlangt dank der Wasserstrahltechnologie eine neue Ausdruckskraft. Jede Umsetzung kann einzigartig sein und je nach Raum, in den sie eingefügt werden soll, personalisiert werden. Das Dekor kann jeder gewünschten Größe angepasst werden. Fuge zwischen den Teilen 1 mm. Zur Umsetzung des Projekts wird der Plan des Kunden mit genauer Angabe der Maße der zu verkleidenden Wand benötigt. Im Falle von nicht perfekt quadratischen Wänden werden die an den Seiten befindlichen Teile 5 cm länger gelassen.

La junta se vuelve decoración, la separación de la materia adquiere una nueva expresión gracias a la tecnología de la propulsión por chorro de agua. Toda realización puede ser única y personalizada en base al espacio en el que se deberá colocar, la decoración se puede adaptar a cualquier medida requerida. Junta entre las piezas de 1 mm. Para llevar a cabo el proyecto es necesario contar con la planta del cliente, que indica con precisión las medidas de las paredes que hay que revestir. En el caso en el que no se cuente con paredes perfectamente en ángulo agudo, las piezas de los lados tendrán una longitud superior a los 5 cm.

PUZZLE DECOR **160x160** 63"x63" 739829

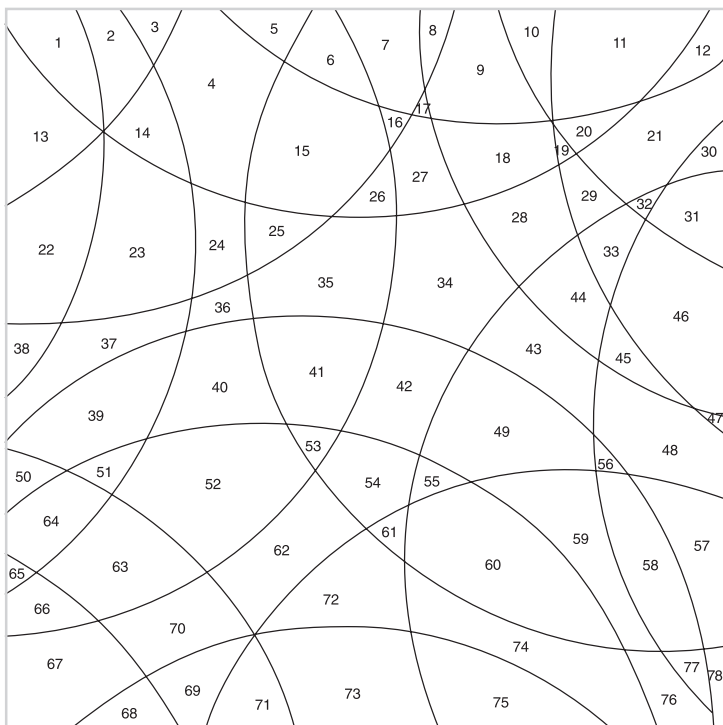

Esempio: per la realizzazione di un pannello di 160x160 cm il consumo sarà di 6 pezzi nel formato 80x80.

Example: covering a 160x160 cm panel will require the use of six 80x80 pieces.









Exemple: pour la réalisation d'un panneau de 160x160 cm, on consommera 6 pièces au format 80x80.

Beispiel: Zur Fertigung einer Platte von 160x160 cm liegt der Verbrauch bei 6 Teilen im Format 80x80.











Ejemplo: para la realización de un panel de 160x160 cm el consumo será de 6 piezas en el formato 80x80.

**GRES FINE PORCELLANATO**

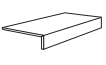
FINE PORCELAIN STONEWARE / GRÈS CÉRAMÉ FIN / FEINSTEINZEUG-KOLLEKTIONEN / GRES PORCELÁNICO FINO  
SQUADRATO - SQUARED - EQUARRI - REKTIFIZIERT - ESCUADRADO

9 mm 3/8" ↑↓		COLOR	SURFACE	30x30 11 4/5" x 11 4/5"  mosaico tessere 3x3	COLOR	SURFACE	15x60 6" x 23 5/8"  modulo listello mix 3D
<b>INDUSTRIAL</b>		IVORY	NATURALE/MATTE	739130	IVORY/TAUPE/MOKA	SOFT	739191
		TAUPE	NATURALE/MATTE	739133	SAGE/STEEL/PLOMB	SOFT	739190
		MOKA	NATURALE/MATTE	739134			
		SAGE	NATURALE/MATTE	739131			
		STEEL	NATURALE/MATTE	739132			
		PLOMB	NATURALE/MATTE	739135			











PEZZI SPECIALI/SPECIAL TRIMS/PIÈCES SPÉCIALES/FORMSTÜCKE/PIEZAS ESPECIALES

9 mm 3/8" ↑↓		COLOR	SURFACE	4,6x60 1 4/5" x 23 5/8"  battiscopa	33x120x3 13" x 47 1/4" x 1 1/8"  gradino	33x120x3 13" x 47 1/4" x 1 1/8"  angolo gradino dx	33x120x3 13" x 47 1/4" x 1 1/8"  angolo gradino sx	33x120x3 13" x 47 1/4" x 1 1/8"  angolo gradino dx/sx	15x60x6 6" x 23 5/8" x 2 1/2"  elemento elle
<b>INDUSTRIAL</b>		IVORY	NATURALE/MATTE	745535	739142	739148	739154	739422	-
			SOFT	745541	739160	739166	739172	739428	-
			BOCCIARDATO BUSH-HAMMERED	-	-	-	-	-	739136
		TAUPE	NATURALE/MATTE	745540	739145	739151	739157	739425	-
			SOFT	745546	739163	739169	739175	739431	-
			BOCCIARDATO BUSH-HAMMERED	-	-	-	-	-	739139
		MOKA	NATURALE/MATTE	745536	739146	739152	739158	739426	-
			SOFT	745542	739164	739170	739176	739432	-
			BOCCIARDATO BUSH-HAMMERED	-	-	-	-	-	739140
		SAGE	NATURALE/MATTE	745538	739143	739149	739155	739423	-
			SOFT	745544	739161	739167	739173	739429	-
			BOCCIARDATO BUSH-HAMMERED	-	-	-	-	-	739137
		STEEL	NATURALE/MATTE	745539	739144	739150	739156	739424	-
			SOFT	745545	739162	739168	739174	739430	-
			BOCCIARDATO BUSH-HAMMERED	-	-	-	-	-	739138
		PLOMB	NATURALE/MATTE	745537	739147	739153	739159	739427	-
			SOFT	745543	739165	739171	739177	739433	-
			BOCCIARDATO BUSH-HAMMERED	-	-	-	-	-	739141

**GRES FINE PORCELLANATO**

FINE PORCELAIN STONEWARE / GRÈS CÉRAME FIN / FEINSTEINZEUG-KOLLEKTIONEN / GRES PORCELÁNICO FINO  
SQUADRATO - SQUARED - EQUARRI - REKTIFIZIERT - ESCUADRADO

PEZZI SPECIALI/SPECIAL TRIMS  
PIÈCES SPÉCIALES/FORMSTÜCKE  
PIEZAS ESPECIALES

6 mm 1/4"				30x30 11 4/5"x11 4/5"	30x30 11 4/5"x11 4/5"	30x30 11 4/5"x11 4/5"	4,6x80 1 4/5"x3 1/2"
	COLOR	SURFACE	 mosaico tessere 7,5x7,5	 muretto tessere 7,5x15	 mosaico tessere 1,5x3	 battiscopa	
<b>INDUSTRIAL</b>		IVORY	NATURALE/MATTE	747722	747732	747742	747857
		TAUPE	NATURALE/MATTE	747723	747733	747743	747858
		MOKA	NATURALE/MATTE	747724	747734	747744	747859
		SAGE	NATURALE/MATTE	747725	747735	747745	747860
		STEEL	NATURALE/MATTE	747726	747736	747746	747861
		PLOMB	NATURALE/MATTE	747727	747737	747747	747862

**INDUSTRIAL**

**Per un effetto ottimale della posa, florim suggerisce di mantenere 2 mm di fuga per pose monofornate e 3 mm per combinare formati misti** - For optimal installation results, florim recommends maintaining a joint of 2 mm 1/12" for single format installations and 3 mm 1/8" to combine mixed formats. - Pour réaliser une pose parfaite, florim suggère de maintenir 2 mm de joint pour la pose des monofornats, et 3 mm pour les combinaisons de formats mixtes. - Um einen optimalen effekt beim verlegen zu erzielen empfiehlt florim eine 2 mm fugen bei einformatigen verlegungen und 3 mm fugen bei formatkombinationen Para lograr los máximos resultados en la posa del producto, florim aconseja 2 mm de junta en aplicaciones monofornate y 3 mm en combinaciones de formatos mixtos

**In relazione alle differenti tecnologie produttive l'accostamento di prodotti con spessori diversi potrebbe presentare delle disomogeneità, se ne sconsiglia pertanto l'abbinamento.** / Due to the different production technologies, contiguous installation of products with different thickness may give a non-homogeneous result. For this reason we do not recommend this option. / Vu que différentes technologies de production sont utilisées avec des épaisseurs différentes, des problèmes d'homogénéité pourraient se présenter, il est donc déconseillé de les poser ensemble. / Wegen unterschiedlicher Produktionstechnologien können die Fliesen mit verschiedenen Materialstärken optische Differenzen aufweisen. Von einem direkten Aneinanderlegen wird deshalb abgeraten. / Dadas las diferentes tecnologías productivas, la combinación de productos de diferentes espesores podría dar lugar a heterogeneidad, por lo que se desaconseja mezclarlas.

# INDUSTRIAL OUTDOOR

## Vantaggi tecnici - Technical advantages - Avantages techniques Technische Vorteile - Ventajas técnicas

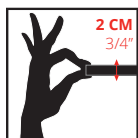

- Lastra monolitica compatta di spessore 2 cm squadrata e rettificata
- Compact monolithic slab 2 cm thick squared and rectified
- Dalle monolithique compacte de 2 cm d'épaisseur, égarriée et rectifiée
- Kompakte monolithische Platte, 2 cm dick, rechteckig und scharfkantig geschliffen
- Losa monolítica compacta de 2 cm de espesor, esquadrada y rectificada.



- INGELIVO
- FROST RESISTANT
- INGÉLIF
- FROSTBESTÄNDIG
- RESISTENTE A LA HELADA



- ELEVATA RESISTENZA AI CARICHI STATICI
- HIGH STATIC LOAD RESISTANCE
- RÉSISTANCE ÉLEVÉE AUX CHARGES STATIQUES
- HOHE STATISCHE BELASTBARKEIT
- ELEVADA RESISTENCIA A LAS CARGAS ESTÁTICAS



- FACILE DA POSARE
- EASY TO INSTALL
- FACILE À POSER
- VERLEGELEICHT
- FÁCIL DE COLOCAR



- ANTISCIVOLO R11
- ANTI SLIP R11
- ANTIDÉRAPANT R11
- RUTSCHFEST R11
- ANTIDESLIZANTE R11

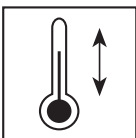

- RESISTENTE AGLI SBALZI TERMICI
- THERMAL SHOCK RESISTANT
- RÉSISTANT AUX ÉCARTS THERMIQUES
- TEMPERATURWECHSELBESTÄNDIG
- RESISTENTE A LAS OSCILACIONES TÉRMICAS



- FACILE DA PULIRE
- EASY TO CLEAN
- FACILE À NETTOYER
- REINIGUNGSLEICHT
- FÁCIL DE LIMPIAR

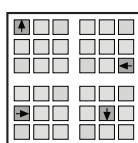

- RIMOVIBILE E RIUTILIZZABILE
- REMOVABLE AND REUSABLE
- DÉMONTABLE ET RÉUTILISABLE
- ENTFERNBAR UND WIEDERVERWENDBAR
- DESMONTABLE Y REUTILIZABLE



- INATTACCABILE DA AGENTI CHIMICI E MUFFE
- IMPERVIOUS TO ATTACK BY CHEMICALS OR MOULD
- RÉSISTANT AUX AGENTS CHIMIQUES ET AUX MOISSISSURES
- UNANGREIFBAR DURCH CHEMISCHE STOFFE UND SCHIMMEL
- RESISTENTE A LOS AGENTES QUÍMICOS Y A LOS MOHOS

## Applicazioni - Applications - Applications - Verlegung - Aplicaciones

- Posa diretta su erba
- Direct installation on grass
- Pose direct sur de l'herbe
- Verlegung direkt auf Rasen
- Colocación directa sobre hierba

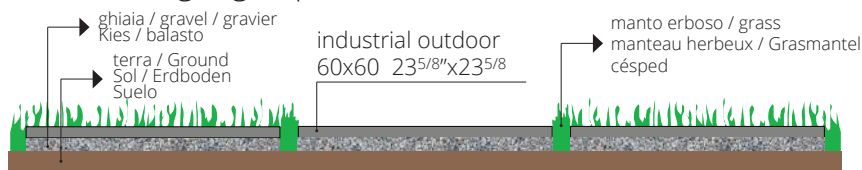

- Posa diretta su ghiaia
- Direct installation over gravel
- Pose direct sur du gravier
- Verlegung direkt auf Kies
- Colocación directa sobre grava



- Posa su massetto cementizio
- Installation on sand-cement screed
- Pose sur chape ciment
- Verlegung auf Zement-Unterbetonblock
- Colocación sobre contrapiso de hormigón

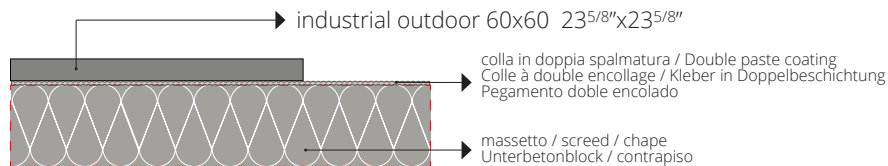

- Posa su piedini fissi o regolabili
- Installation on fixed or adjustable feet
- Pose sur pieds fixes ou réglables
- Verlegung auf feststehende oder regulierbare Füße
- Colocación sobre pies fijos o regulables

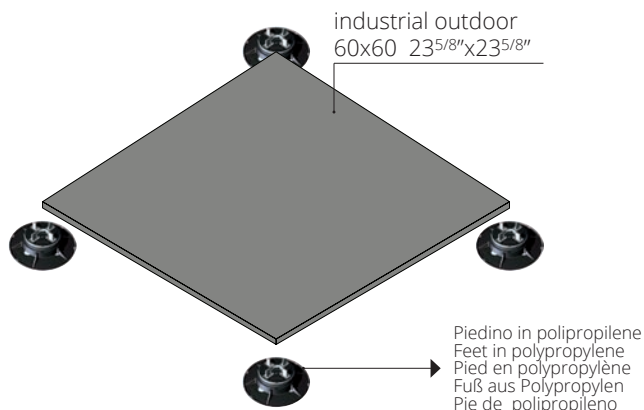

Per le specifiche di utilizzo dei sistemi sopraelevati vedi il sito florim.com  
For the specifics on use of raised systems visit the site florim.com  
Pour les caractéristiques d'utilisation des systèmes surélevés, voir le site florim.com  
Für die Nutzungsbedingungen der Doppelbodensysteme siehe Webseite florim.com  
Para las especificaciones de empleo de los sistemas sobreelevados consulte el sitio web florim.com

Le lastre ceramiche sono sottoposte a un trattamento di compattazione termica che assicura resistenza e durata nel tempo. Il bassissimo assorbimento d'acqua rende perciò il materiale ingelivo. Ciò può comportare ristagni d'acqua superficiali anche per materiale installato a regola d'arte. / Ceramic tiles undergo a compacting thermal treatment that ensures resistance and durability. The low level of water absorption makes the slabs frost resistant. This could result in superficial water stagnations even if materials are installed in a workmanlike manner. / Les carreaux de céramique subissent un traitement thermique de compactage qui assure résistance et durabilité. Le bas niveau d'absorption d'eau rend les dalles résistant au gel. Il pourrait en résulter des stagnations d'eau superficielles, même si les dalles ont été installées dans les règles de l'art. / Die Keramikplatten werden einer thermischen Verdichtung unterzogen, welche die Widerstandsfähigkeit und Langlebigkeit sichert. Die extrem niedrige Wasseraufnahme macht das Material frostsicher. Die hohe Materialdichte kann, auch bei einer perfekten Verlegung, eine längere Abtrochnungszeit von angestaumtem Wasser zur Folge haben. / Las baldosas cerámicas se someten a un tratamiento de compactación térmica que asegura resistencia y durabilidad. La baja absorción de agua hace que las baldosas resistan al hielo. Esto podría resultar en estancamientos superficiales de agua, incluso si los materiales están instalados según las reglas del arte.



IVORY



TAUPE



MOKA



SAGE

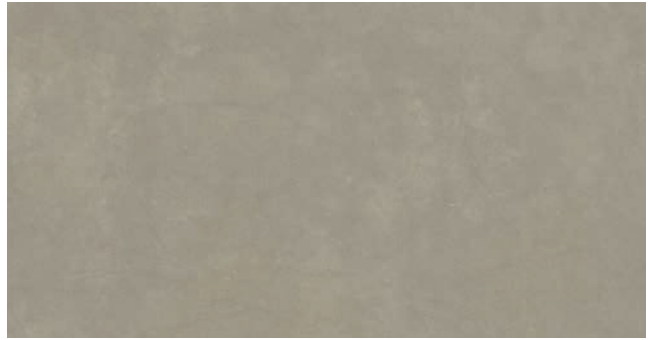

STEEL









PLOMB



INDUSTRIAL











**GRES FINE PORCELLANATO**  
 FINE PORCELAIN STONEWARE/GRES CERAME FIN/FEINSTEINZEUG-KOLLEKTIONEN/GRES PORCELANICO FINO  
 SQUADRATO - SQUARED - EQUARRI - REKTIFIZIERT - ESCUADRADO

20 mm 3/4" ↑ ↓		COLOR	SURFACE	60x60 23 <sup>5/8</sup> "x23 <sup>5/8</sup> "
INDUSTRIAL		IVORY	BOCCIARDATO BUSH-HAMMERED	738961
		TAUPE	BOCCIARDATO BUSH-HAMMERED	738964
		MOKA	BOCCIARDATO BUSH-HAMMERED	738965
		SAGE	BOCCIARDATO BUSH-HAMMERED	738962
		STEEL	BOCCIARDATO BUSH-HAMMERED	738963
		PLOMB	BOCCIARDATO BUSH-HAMMERED	738966

# INDUSTRIAL

GRES FINE PORCELLANATO/FINE PORCELAIN STONWARE/GRES CERAME FIN/FEINSTEINZEUG-KOLLEKTIONEN/GRES PORCELANICO FINO  
SQUADRATO - SQUARED - EQUARRI - REKTIFIZIERT - ESCUADRADO

20 mm 3/4" ↑↓

CARATTERISTICHE TECNICHE - TECHNICAL CHARACTERISTICS - CARACTERISTIQUES TECHNIQUES - TECHNISCHE EIGENSCHAFTEN - CARACTERÍSTICAS TÉCNICAS						
	Lastre in gres fine porcellanato non smaltato. Piastrelle di ceramica pressate a secco. Caratteristiche di qualità secondo i test di controllo previsti dalla norma EN 14411-ISO 13006 Appendice G gruppo Bia UGL/ Unglazed porcelain stoneware slabs. Dry-pressed ceramic tiles. Quality specifications, according to control tests of EN 14411-ISO 13006 Appendix G group Bia UGL. / Dalles en gres cérame fin non émaillée. Carreaux céramiques pressés à sec. Caractéristiques de qualité d'après les essais de contrôle norme EN 14411-ISO 13006 Appendice G groupe Bia UGL/ Nicht glasierte und vollständig gesinterte Feinsteinzeugplatten. Trocken gepresste Keramikfliesen. Qualitätseigenschaften nach Normen EN 14411-ISO 13006 Anhang G Gruppe Bia UGL/ Planchas de gres porcelánico fino no esmaltado. Baldosas de cerámica resadas en seco. Características de calidad según las Normas EN 14411-ISO 13006 Apéndice G grupo Bia UGL.	PRESCRIZIONE STANDARD REQUIREMENTS PRESCRIPTIONS ANFORDERUNGEN PRESCRIPTION		RISULTATI TESTS TEST RESULTS RESULTATS DES ESSAIS PRÜFERGEBNIS RESULTADOS TESTS	RIFERIMENTO NORMA REFERENCE STANDARD RÉFÉRENCE NORME STANDARDWERT REFERENCIA NORMA	
		N ≥ 15 cm		BOCCIARDATO		
		(%)	(mm)			
	LUNGHEZZA E LARGHEZZA: DEVIAZIONE AMMISSIBILE, IN %, DELLA DIMENSIONE MEDIA DI OGNI PIASTRELLA DALLA DIM. DI FABBRICAZIONE / LENGTH AND WIDTH ADMITTED DEVIATION, IN %, OF THE AVERAGE SIZE OF EACH TILE FROM THE PRODUCTION DIMENSIONS / LONGUEUR ET LARGEUR : MARGE DE TOLÉRANCE, EN %, ENTRE LA DIMENSION MOYENNE DE CHAQUE CARREAU ET LA DIM. DE FABRICATION / LANGE UND BREITE: ZULÄSSIGE ABWEICHUNG DES DURCHSCHNITTMÄßES JEDER FLIESE VOM HERSTELLMAß IN PROZENTEN / LARGO Y ANCHO: DESVIACION ADMISIBLE, EN %, DEL TAMAÑO MEDIO DE CADA BALDOSA A PARTIR DEL TAMAÑO DE FABRICACIÓN.	Squadrato ISO 13006	±0,3 %	±1,0 mm	±0,15 %	ISO 10545-2
	DEVIAZIONE AMMISSIBILE, IN PERCENTO, DELLO SPESSORE MEDIO DI OGNI PIASTRELLA DALLA DIMENSIONE DI FABBRICAZIONE / ADMITTED DEVIATION, IN %, OF THE AVERAGE THICKNESS OF EACH TILE FROM THE PRODUCTION DIMENSIONS / MARGE DE TOLÉRANCE EN POURCENTAGE, ENTRE L'ÉPAISSEUR MOYENNE DE CHAQUE CARREAU ET LA DIMENSION DE FABRICATION / ZULÄSSIGE ABWEICHUNG DER DURCHSCHNITTSSTÄRKE JEDER FLIESE VOM HERSTELLMAß IN PROZENTEN / DESVIACION ADMISIBLE, EN TANTO POR CIENTO, DEL GROSOR MEDIO DE CADA BALDOSA A PARTIR DEL TAMAÑO DE FABRICACIÓN.	Squadrato ISO 13006	±5 %	±0,5 mm	±5 %	
	DEVIAZIONE MASSIMA DI RETTILINEARITÀ, IN PERCENTO, IN RAPPORTO ALLE DIMENSIONI DI FABBRICAZIONE CORRISPONDENTI / MAXIMUM STRAIGHTNESS DEVIATION, IN %, IN RELATION TO THE CORRESPONDING PRODUCTION DIMENSIONS / MARGE DE TOLÉRANCE EN POURCENTAGE, PAR RAPPORT AUX DIMENSIONS DE FABRICATION CORRESPONDANTES / ZULÄSSIGE HOCHSTABWEICHUNG DER KANTENGERADHEIT IM VERHÄLTNIS ZU DEN ENTSPRECHENDEN HERSTELLMÄßEN IN PROZENTEN / DESVIACION MÁXIMA DE RECTITUD, EN TANTO POR CIENTO, EN RELACION CON EL TAMAÑO DE FABRICACIÓN CORRESPONDIENTE.	Squadrato ISO 13006	±0,3 %	±0,8 mm	±0,10 %	
	DEVIAZIONE MASSIMA DI ORTOGONALITÀ, IN PERCENTO, IN RAPPORTO ALLE DIMENSIONI DI FABBRICAZIONE CORRISPONDENTI / MAXIMUM RIGHT-ANGLE DEVIATION, IN %, IN RELATION TO THE CORRESPONDING PRODUCTION DIMENSIONS / MARGE DE TOLÉRANCE D'ANGULARITÉ, EN POURCENTAGE, PAR RAPPORT AUX DIMENSIONS DE FABRICATION / HOCHSTABWEICHUNG DER RECHTWINKLIGKEIT IM VERHÄLTNIS ZU DEN ENTSPRECHENDEN HERSTELLMÄßEN IN PROZENTEN / DESVIACION MÁXIMA DE LA ORTOGONALIDAD, EN TANTO POR CIENTO, EN RELACION CON EL TAMAÑO DE FABRICACIÓN CORRESPONDIENTE.	Squadrato ISO 13006	±0,3 %	±1,5 mm	±0,20 %	
	PLANARITÀ (CURVATURA DEL CENTRO, DELLO SPIGOLO E SVERGOLAMENTO) / FLATNESS (CURVING IN THE MIDDLE, CORNER AND WARPING) / PLANÉITÉ (COUBRE CENTRALE, DE L'ARÊTE ET GAUCHISSEMENT) / EBENFLÄCHIGKEIT (KRÜMMUNG DER MITTE, DER KANTE UND VERWINDUNG) / PLANITUD (CURVATURA DEL CENTRO, DE LA ARISTA Y ABARQUILLAMIENTO).	Squadrato ISO 13006	±0,4 %	±1,8 mm	±0,35 %	
QUALITÀ DELLA SUPERFICIE - SURFACE QUALITY / QUALITÉ DE LA SURFACE - QUALITÄT DER OBERFLÄCHE / CALIDAD DE LA SUPERFICIE.	IL 95% MIN DELLE PIASTRELLE DEVE ESSERE ESENTE DA DIFETTI VISIBILI. / AT LEAST 95% OF THE TILES MUST BE FREE FROM VISIBLE FLAWS. 95% MIN DES CARREAUX DOIVENT PRÉSENTER AUCUN DÉFAUT VISIBLE. MINDESTENS 95% DER FLIESEN MÜSSEN FREI VON SICHTBAREN MÍN. / EL 95% DE LAS BALDOSAS TIENE QUE ESTAR EXENTO DE DEFECTOS VISIBLES.			CONFORME/CONFORMING CONFORME/KONFORM CONFORME.		
	MASSA D'ACQUA ASSORBITA IN % / % WATER ABSORPTION - MASSE D'EAU ABSORBÉE EN % / WASSERAUFNAHME IN % MASA DE AGUA ABSORBIDA EN %		E ≤ 0,5 %		valore medio 0,08 %	ISO 10545-3
	FORZA DI ROTTURA IN N (sp. ≥ 7,5 mm) - BREAKING STRENGTH IN N (thickness ≥ 7,5 mm) / FORCE DE RUPTURE EN N (ép. ≥ 7,5 mm) / BRUCHLAST IN N (Dicke ≥ 7,5 mm) / FUERZA DE ROTURA EN N (gr. ≥ 7,5 mm)		1300 min		valore medio 14000 N	ISO 10545-4
	RESISTENZA ALLA FLESSIONE IN N/mm² / N/mm² FLEXURAL STRENGTH TEST / RÉSISTANCE A LA FLEXION EN N/mm² / BIEGEFESTIGKEIT IN N/mm²		> 35 N/mm²		valore medio 52 N/mm²	ISO 10545-4
	RESISTENZA ALL'ABRASIONE PROFONDA DELLE PIASTRELLE NON SMALTATE / RESISTANCE TO DEEP ABRASION OF UNGLAZED TILES / RÉSISTANCE A L'ABRASION PROFONDE DES CARREAUX NON ÉMAILLÉS / TIEFENABRIEBFESTIGKEIT UNGLASIERTER FLIESEN / RESISTENCIA A LA ABRASION PROFUNDA DE LAS BALDOSAS SIN ESMALTAR		< 175 mm³		valore medio 140 mm³	ISO 10545-6
	RESISTENZA AGLI SBALZI TERMICI / THERMAL SHOCKS RESISTANT / RÉSISTANCE AUX VARIATIONS THERMIQUES TEMPERATURWECHSELBESTÄNDIGKEIT / RESISTENCIA AL CHOQUE TÉRMICO.		METODO DI PROVA DISPONIBILE / AVAILABLE TESTING METHOD / METHODE D'ESSAI DISPONIBLE / VERFUGBARE PRÜFMETHODE / MÉTODO DE ENSAYO DISPONIBLE		RESISTE - RÉSISTANT RÉSISTE - ERFÜLLT RESISTE	ISO 10545-9
	RESISTENZA ALLE MACCHIE / RESISTANCE TO STAINING / RÉSISTANCE AUX TACHES / FLECKENABWEISEND RESISTENCIA A LAS MANCHAS		METODO DI PROVA DISPONIBILE / AVAILABLE TESTING METHOD / METHODE D'ESSAI DISPONIBLE / VERFUGBARE PRÜFMETHODE / MÉTODO DE ENSAYO DISPONIBLE		Classe 4	ISO 10545-14
	RESISTENZA A BASSE CONCENTRAZIONI DI ACIDI E ALCALI. / RESISTANCE TO LOW CONCENTRATIONS OF ACIDS AND ALKALIS. / RÉSISTANCE A BASSES CONCENTRATIONS D'ACIDES ET ALCALIS. / WIDERSTAND GEGEN NIEDRIGE KONZENTRATIONEN VON SAUREN UND LAUGEN. / RESISTENCIA A BAJAS CONCENTRACIONES DE ACIDOS Y ALCALIS.		COME DICHIARATO DAL PRODUTTORE SEE MANUFACTURER'S DECLARATION SELON DÉCLARATION DU PRODUCTEUR ENTSPRECHEND DER HERSTELLERANGABEN TAL COMO DECLARA EL FABRICANTE		LA	ISO 10545-13
	RESISTENZA A ALTE CONCENTRAZIONI DI ACIDI ED ALCALI / RESISTANCE TO HIGH CONCENTRATIONS OF ACIDS AND ALKALIS / RÉSISTANCE À HAUTES CONCENTRATIONS D'ACIDES ET BASES / BESTÄNDIGKEIT GEGEN STARK KONZENTRIERTE SAURE UND LAUGEN / RESISTENCIA A ALTAS CONCENTRACIONES DE ACIDOS Y ALCALIS		METODO DI PROVA DISPONIBILE / AVAILABLE TESTING METHOD / METHODE D'ESSAI DISPONIBLE / VERFUGBARE PRÜFMETHODE / MÉTODO DE ENSAYO DISPONIBLE		HA	
	RESISTENZA AI PRODOTTI CHIMICI DI USO DOMESTICO E AGLI ADDITIVI PER PISCINA / RESISTENCE TO DOMESTIC CHEMICAL PRODUCTS AND ADDITIVES FOR SWIMMING POOLS / RÉSISTANT AUX PRODUITS CHIMIQUES À USAGE DOMESTIQUE ET AUX ADDITIFS POUR PISCINE / WIDERSTAND GEGEN HAUSHALTSCHEMIKALIEN UND SCHWIMMBADZUSATZSTOFFEN / RESISTENCIA A PRODUCTOS PARA LIMPIEZA DOMESTICA Y ADITIVOS PARA PISCINAS		B min		A	
	RESISTENZA AL GELO / FROST RESISTANCE - RÉSISTANCE AU GEL / FROSTSICHERHEIT - RESISTENCIA A LA HELADA		RICHIESTA / REQUIRED REQUISSE / GEFORDET / REQUERIDA		RESISTE - RÉSISTANT RÉSISTE - ERFÜLLT - RESISTE	ISO 10545-12
	COEFFICIENTE D'ATTRITO (SCIVOLOSITÀ) / FRICTION COEFFICIENT (SLIPPERINESS) / COEFFICIENT DE FRICTION (GLISSEMENT) / REIBUNGSKOEFFIZIENT (SCHLÜPFRIEGKEIT) - COEFICIENTE DE ANTI DESLIZAMIENTO				> 0,42 wet	ANSI A 326.3
					α ≥ 24° classe C	DIN EN 16165 ANNEX A
					19° < α ≤ 27° R11	DIN EN 16165 ANNEX B

Per un effetto ottimale della posa, florim suggerisce di mantenere 2 mm di fuga per pose monofornate e 3 mm per combinare formati misti / For optimal installation results, florim recommends maintaining a joint of 2 mm 1/2" for single format installations and 3 mm 1/8" to combine mixed formats / Pour réaliser une pose parfaite, florim suggère de maintenir 2 mm de joint pour la pose des monofornats, et 3 mm pour les combinaisons de formats mixtes / Um einen optimalen effekt beim verlegen zu erzielen empfehlt florim eine 2 mm fugе bei einformatigen verlegungen und 3 mm fugе bei formatkombinationen / Para lograr los máximos resultados en la posa del producto, florim aconseja 2 mm de junta en aplicaciones monofornato y 3 mm en combinaciones de formatos mixtos.

# INDUSTRIAL

GRES FINE PORCELLANATO/FINE PORCELAIN STONWARE/GRES CERAME FIN/FEINSTEINZEUG-KOLLEKTIONEN/GRES PORCELANICO FINO  
SQUADRATO - SQUARED - EQUARRI - REKTIFIZIERT - ESCUADRADO

9 mm 3/8"

CARATTERISTICHE TECNICHE - TECHNICAL CHARACTERISTICS - CARACTERISTIQUES TECHNIQUES - TECHNISCHE EIGENSCHAFTEN - CARACTERÍSTICAS TÉCNICAS











Lastre in gres fine porcellanato non smaltato. Piastrelle di ceramica pressate a secco. Caratteristiche di qualità secondo i test di controllo previsti dalla norma EN 14411-ISO 13006 Appendice G gruppo Bia UGL/ Unglazed porcelain stoneware slabs. Dry-pressed ceramic tiles. Quality specifications, according to control tests of EN 14411-ISO 13006 Appendix G group Bia UGL. / Dalles en grès cérame fin non émaillé. Carreaux céramiques pressés à sec. Caractéristiques de qualité d'après les essais de contrôle norme EN 14411-ISO 13006 Appendice G groupe Bia UGL/ Nicht glasierte und vollständig gesinterte Feinsteinzeugplatten. Trocken gepresste Keramikfliesen. Qualitätseigenschaften nach Normen EN 14411-ISO 13006 Anhang G Gruppe Bia UGL/ Planchas de gres porcelánico fino no esmaltado. Baldosas de cerámica resnadas en seco. Características de calidad según las Normas EN 14411-ISO 13006 Apéndice G grupo Bia UGL.		PRESCRIZIONE STANDARD REQUIREMENTS PRESCRIPTIONEN ANFORDERUNGEN PRESCRIPCION		RISULTATI TESTS TEST RESULTS RESULTATS DES ESSAIS PRÜFERGEBNIS RESULTADOS TESTS			RIFERIMENTO NORMA REFERENCE STANDARD RÉFÉRENCE NORME STANDARDWERT REFERENCIA NORMA
		N > 15 cm		SOFT	NATURALE	BOCCIARDATO	
		(%)	(mm)				
	LUNGHEZZA E LARGHEZZA: DEVIAZIONE AMMISSIBILE, IN %, DELLA DIMENSIONE MEDIA DI OGNI PIASTRELLA DALLA DIM. DI FABBRICAZIONE / LENGTH AND WIDTH: ADMITTED DEVIATION, IN %, OF THE AVERAGE SIZE OF EACH TILE FROM THE PRODUCTION DIMENSIONS / LONGUEUR ET LARGEUR : MARGE DE TOLÉRANCE, EN %, ENTRE LA DIMENSION MOYENNE DE CHAQUE CARREAU ET LA DIM. DE FABRICATION / LANGE UND BREITE: ZULASSIGE ABWEICHUNG DES DURCHSCHNITTMÄßES JEDER FLIESE VOM HERSTELLMÄß IN PROZENTEN / LARGO Y ANCHO: DESVIACION ADMISIBLE, EN %, DEL TAMAÑO MEDIO DE CADA BALDOSA A PARTIR DEL TAMAÑO DE FABRICACIÓN.	Squadrato ISO 13006	±0,3 %	±1,0 mm		±0,15 %	ISO 10545-2
	DEVIAZIONE AMMISSIBILE, IN PERCENTO, DELLO SPESORE MEDIO DI OGNI PIASTRELLA DALLA DIMENSIONE DI FABBRICAZIONE / ADMITTED DEVIATION, IN %, OF THE AVERAGE THICKNESS OF EACH TILE FROM THE PRODUCTION DIMENSIONS / MARGE DE TOLÉRANCE, EN POURCENTAGE, ENTRE L'ÉPAISSEUR MOYENNE DE CHAQUE CARREAU ET LA DIMENSION DE FABRICATION / ZULASSIGE ABWEICHUNG DER DURCHSCHNITTSDICKE JEDER FLIESE VOM HERSTELLMÄß IN PROZENTEN / DESVIACION ADMISIBLE, EN TANTO POR CIENTO, DEL GROSOR MEDIO DE CADA BALDOSA A PARTIR DEL TAMAÑO DE FABRICACIÓN.	Squadrato ISO 13006	±5 %	±0,5 mm		±5 %	
	DEVIAZIONE MASSIMA DI RETTILINEARITÀ, IN PERCENTO, IN RAPPORTO ALLE DIMENSIONI DI FABBRICAZIONE CORRISPONDENTI / MAXIMUM STRAIGHTNESS DEVIATION, IN %, IN RELATION TO THE CORRESPONDING PRODUCTION DIMENSIONS / MARGE DE TOLÉRANCE DE RECTITUDE, EN POURCENTAGE, PAR RAPPORT AUX DIMENSIONS DE FABRICATION CORRESPONDANTES / ZULASSIGE HOCHSTABWEICHUNG DER KANTENGERADHEIT IM VERHÄLTNIS ZU DEN ENTSPRECHENDEN HERSTELLMÄßEN IN PROZENTEN / DESVIACION MÁXIMA DE RECTITUD, EN TANTO POR CIENTO, EN RELACION CON EL TAMAÑO DE FABRICACIÓN CORRESPONDIENTE.	Squadrato ISO 13006	±0,3 %	±0,8 mm		±0,10 %	
	DEVIAZIONE MASSIMA DI ORTOGONALITÀ, IN PERCENTO, IN RAPPORTO ALLE DIMENSIONI DI FABBRICAZIONE CORRISPONDENTI / MAXIMUM RIGHT-ANGLE DEVIATION, IN %, IN RELATION TO THE CORRESPONDING PRODUCTION DIMENSIONS / MARGE DE TOLÉRANCE D'ANGULARITÉ, EN POURCENTAGE, PAR RAPPORT AUX DIMENSIONS DE FABRICATION / HOCHSTABWEICHUNG DER RECHTWINKLIGKEIT IM VERHÄLTNIS ZU DEN ENTSPRECHENDEN HERSTELLMÄßEN IN PROZENTEN / DESVIACION MÁXIMA DE LA ORTOGONALIDAD, EN TANTO POR CIENTO, EN RELACION CON EL TAMAÑO DE FABRICACIÓN CORRESPONDIENTE.	Squadrato ISO 13006	±0,3 %	±1,5 mm		±0,20 %	
	PLANARITÀ (CURVATURA DEL CENTRO, DELLO SPIGOLO E SVERGOLAMENTO) / FLATNESS (CURVING IN THE MIDDLE, CORNER AND WARPING) / PLANEITÉ (COURBURE CENTRALE, DE L'ARÊTE ET GAUCHISSEMENT) / EBENFLÄCHIGKEIT (KRÜMMUNG DER MITTE, DER KANTE UND VERWINDUNG) / PLANITUD (CURVATURA DEL CENTRO, DE LA ARISTA Y ABARQUILLAMIENTO).	Squadrato ISO 13006	±0,4 %	±1,8 mm		±0,35 %	
QUALITÀ DELLA SUPERFICIE - SURFACE QUALITY / QUALITÉ DE LA SURFACE - QUALITÄT DER OBERFLÄCHE / CALIDAD DE LA SUPERFICIE.	IL 95% MIN DELLE PIASTRELLE DEVE ESSERE ESENTE DA DIFETTI VISIBILI. / AT LEAST 95% OF THE TILES MUST BE FREE FROM VISIBLE FLAWS. 95% MIN DES CARREAUX NE DOIVENT PRÉSENTER AUCUN DÉFAUT VISIBLE. MINDESTENS 95% DER FLIESEN MÜSSEN FREI VON SICHTBAREN MIN. / EL 95% DE LAS BALDOSAS TIENE QUE ESTAR EXENTO DE DEFECTOS VISIBLES.		CONFORME/CONFORMING CONFORME/KONFORM CONFORME.				
MASSA D'ACQUA ASSORBITA IN % / % WATER ABSORPTION - MASSE D'EAU ABSORBÉE EN % WASSERAUFNAHME IN % MASA DE AGUA ABSORBIDA EN %		≤0,5 %			valore medio 0,08 %	ISO 10545-3	
FORZA DI ROTTURAZIONE (sp. ≥ 7,5 mm) - BREAKING STRENGTH IN N (thickness ≥ 7,5 mm) / FORCE DE RUPTURE EN N (ép. ≥ 7,5 mm) / BRUHLAST IN N (Dicke ≥ 7,5 mm) / FUERZA DE ROTURA EN N (gr. ≥ 7,5 mm)		1300 min			valore medio 2200 N	ISO 10545-4	
RESISTENZA ALLA FLESSIONE IN N/mm² / N/mm² FLEXURAL STRENGTH TEST / RÉSISTANCE A LA FLEXION EN N/mm² / BIEGEFESTIGKEIT IN N/mm² / RESISTENCIA A LA FLEXIÓN EN N/mm²		> 35 N/mm²			valore medio 50 N/mm²	ISO 10545-4	
RESISTENZA ALL'ABRASIONE PROFONDA DELLE PIASTRELLE NON SMALTATE / RESISTANCE TO DEEP ABRASION OF UNGLAZED TILES / RÉSISTANCE À L'ABRASION PROFONDE DES CARREAUX NON ÉMALLÉS / TIEFENABRIEBFESTIGKEIT UNGLASIERTER FLIESEN / RESISTENCIA A LA ABRASIÓN PROFUNDA DE LAS BALDOSAS SIN ESMALTAR		<175 mm³			valore medio 140 mm³	ISO 10545-6	
RESISTENZA A GLI SBALZATERMICI / THERMAL SHOCKS RESISTANT / RÉSISTANCE AUX VARIATIONS THERMIQUES TEMPERATURWECHSELBESTÄNDIGKEIT / RESISTENCIA AL CHOQUE TÉRMICO.	METODO DI PROVA DISPONIBILE / AVAILABLE TESTING METHOD MÉTHODE D'ESSAI DISPONIBLE / VERFÜGBARE PRÜFMETHODE / MÉTODO DE ENSAYO DISPONIBLE		RESISTE - RÉSISTANT RÉSISTE - ERFÜLLT - RESISTE			ISO 10545-9	
RESISTENZA ALLE MACCHIE / RESISTANCE TO STAINING / RÉSISTANCE AUX TACHES / FLECKENABWEISEND RESISTENCIA A LAS MANCHAS	METODO DI PROVA DISPONIBILE / AVAILABLE TESTING METHOD MÉTHODE D'ESSAI DISPONIBLE / VERFÜGBARE PRÜFMETHODE / MÉTODO DE ENSAYO DISPONIBLE		Classe 3-4			ISO 10545-14	
	RESISTENZA A BASSE CONCENTRAZIONI DI ACIDI E ALCALI. / RESISTANCE TO LOW CONCENTRATIONS OF ACIDS AND ALKALIS / RÉSISTANCE A BASSES CONCENTRATIONS D'ACIDES ET ALCALIS / WIDERSTAND GEGEN NIEDRIGE KONZENTRATIONEN VON SÄUREN UND LAUGEN. / RESISTENCIA A BAJAS CONCENTRACIONES DE ÁCIDOS Y ALCALIS.	COME DICHIARATO DAL PRODUTTORE SEE MANUFACTURER'S DECLARATION SELON DÉCLARATION DU PRODUCTEUR ENTSPRECHEND DER HERSTELLERANGABEN TAL COMO DECLARA EL FABRICANTE		LA-LB	LA	LA	ISO 10545-13
	RESISTENZA A ALTE CONCENTRAZIONI DI ACIDI ED ALCALI / RESISTANCE TO HIGH CONCENTRATIONS OF ACIDS AND ALKALIS / RÉSISTANCE À DE HAUTES CONCENTRATIONS D'ACIDES ET BASES / BESTÄNDIGKEIT GEGEN STARK KONZENTRIERTE SÄUREN UND LAUGEN / RESISTENCIA A ALTAS CONCENTRACIONES DE ÁCIDOS Y ALCALIS	METODO DI PROVA DISPONIBILE / AVAILABLE TESTING METHOD MÉTHODE D'ESSAI DISPONIBLE / VERFÜGBARE PRÜFMETHODE / MÉTODO DE ENSAYO DISPONIBLE		HB	HA	HA	
	RESISTENZA AI PRODOTTI CHIMICI DI USO DOMESTICO E AGLI ADDITIVI PER PISCINA / RESISTENCE TO DOMESTIC CHEMICAL PRODUCTS AND ADDITIVES FOR SWIMMING POOLS / RÉSISTANT AUX PRODUITS CHIMIQUES À USAGE DOMESTIQUE ET AUX ADDITIFS POUR PISCINE / WIDERSTAND GEGEN HAUSHALTSCHIMIKALIEN UND SCHWIMMBADZUSATZSTOFFEN / RESISTENCIA A PRODUCTOS PARA LIMPIEZA DOMESTICA Y ADITIVOS PARA PISCINAS	B min		A			
RESISTENZA AL GELO / FROST RESISTANCE - RÉSISTANCE AU GEL / FROSTSICHERHEIT RESISTENCIA A LA HELADA	RICHIESTA / REQUIRED REQUISE / GEFORDET / REQUERIDA		RESISTE - RÉSISTANT RÉSISTE - ERFÜLLT RESISTE			ISO 10545-12	
			> 0,42 wet			ANSI A 326.3	
			12° ≤ α < 18° classe A	18° ≤ α < 24° classe B	α ≥ 24° classe C	DIN EN 16165 ANNEX A	
	COEFFICIENTE D'ATTRITO (SCIVOLosità) / FRICTION COEFFICIENT (SLIPPERINESS) / COEFFICIENT DE FRICTION (GLISSEMENT) / REIBUNGSKOEFFIZIENT (SCHLUPFRIGKEIT) - COEFICIENTE DE ANTI DESLIZAMIENTO				6° < α ≤ 10° R9	10° < α ≤ 19° R10	19° < α ≤ 27° R11

Per un effetto ottimale della posa, florim suggerisce di mantenere 2 mm di fuga per pose monoformato e 3 mm per combinare formati misti / For optimal installation results, florim recommends maintaining a joint of 2 mm 1/12" for single format installations and 3 mm 1/8" to combine mixed formats / Pour réaliser une pose parfaite, florim suggère de maintenir 2 mm de joint pour la pose des monoformats, et 3 mm pour les combinaisons de formats mixtes / Um einen optimalen effekt beim verlegen zu erzielen empfehlt florim eine 2 mm fugen bei einformatigen verlegungen und 3 mm fugen bei formatkombinationen / Para lograr los máximos resultados en la posa del producto, florim aconseja 2 mm de junta en aplicaciones monoformato y 3 mm en combinaciones de formatos mixtos.

# INDUSTRIAL

GRES FINE PORCELLANATO/FINE PORCELAIN STONWARE/GRES CERAME FIN/FEINSTEINZEUG-KOLLEKTIONEN/GRES PORCELANICO FINO  
SQUADRATO - SQUARED - EQUARRI - REKTIFIZIERT - ESCUADRADO

6 mm 1/4" 

CARATTERISTICHE TECNICHE - TECHNICAL CHARACTERISTICS - CARACTERISTIQUES TECHNIQUES - TECHNISCHE EIGENSCHAFTEN - CARACTERÍSTICAS TÉCNICAS							
	Lastre in gres fine porcellanato non smaltato. Piastrelle di ceramica pressate a secco. Caratteristiche di qualità secondo i test di controllo previsti dalla norma EN 14411-ISO 13006 Appendice G gruppo Bla UGL. / Unglazed porcelain stoneware slabs. Dry-pressed ceramic tiles. Quality specifications, according to control tests of EN 14411-ISO 13006 Appendix G group Bla UGL. / Dalles en gres cérame fin non émaillé. Carreaux céramiques pressés à sec. Caractéristiques de qualité d'après les essais de contrôle norme EN 14411-ISO 13006 Appendice G groupe Bla UGL. / Nicht glasierte und vollständig gesinterte Feinsteinzeugplatten. Trocken gepresste Keramikfliesen. Qualitätseigenschaften nach Normen EN 14411-ISO 13006 Anhang G Gruppe Bla UGL. / Plati de gres porcelanico fino no esmaltado. Baldosas de cerámica resnadas en seco. Características de calidad según las Normas EN 14411-ISO 13006 Apéndice G grupo Bla UGL.	PRESCRIZIONE STANDARD REQUIREMENTS PRESCRIPTIONS ANFORDRINGEREN PRESCRIPTION		RISULTATI TESTS TEST RESULTS RESULTATS DES ESSAIS PRÜFERGEBNIS RESULTADOS TESTS		RIFERIMENTO NORMA REFERENCE STANDARD STANDARDWERT REFERENCIA NORMA	
		N ≥ 15 cm		NATURALE	R+PTV		
		(%)	(mm)				
	LUNGHEZZA E LARGHEZZA: DEVIAZIONE AMMISSIBILE, IN %, DELLA DIMENSIONE MEDIA DI OGNI PIASTRELLA DALLA DIM. DI FABBRICAZIONE / LENGTH AND WIDTH: ADMITTED DEVIATION, IN %, OF THE AVERAGE SIZE OF EACH TILE FROM THE PRODUCTION DIMENSIONS / LONGUEUR ET LARGEUR : MARGE DE TOLÉRANCE, EN %, ENTRE LA DIMENSION MOYENNE DE CHAQUE CARREAU ET LA DIM. DE FABRICATION / LANGE UND BREITE: ZULÄSSIGE ABWEICHUNG DES DURCHSCHNITTMÄßES JEDER FLIESE VOM HERSTELLMAß IN PROZENTEN / LARGO Y ANCHO: DESVIACION ADMISIBLE, EN %, DEL TAMAÑO MEDIO DE CADA BALDOSA A PARTIR DEL TAMAÑO DE FABRICACIÓN.	Squadrato ISO 13006	±0,3 %	±1,0 mm	±0,15 %	ISO 10545-2	
	DEVIAZIONE AMMISSIBILE, IN PERCENTO, DELLO SPESSORE MEDIO DI OGNI PIASTRELLA DALLA DIMENSIONE DI FABBRICAZIONE / ADMITTED DEVIATION, IN %, OF THE AVERAGE THICKNESS OF EACH TILE FROM THE PRODUCTION DIMENSIONS / MARGE DE TOLÉRANCE, EN POURCENTAGE, ENTRE L'ÉPAISSEUR MOYENNE DE CHAQUE CARREAU ET LA DIMENSION DE FABRICATION / ZULÄSSIGE ABWEICHUNG DER DURCHSCHNITTSDICKE JEDER FLIESE VOM HERSTELLMAß IN PROZENTEN / DESVIACION ADMISIBLE, EN TANTO POR CIENTO, DEL GROSOR MEDIO DE CADA BALDOSA A PARTIR DEL TAMAÑO DE FABRICACIÓN.	Squadrato ISO 13006	±5 %	±0,5 mm	±5 %	ISO 10545-2	
	DEVIAZIONE MASSIMA DI RETTILINEARITÀ, IN PERCENTO, IN RAPPORTO ALLE DIMENSIONI DI FABBRICAZIONE CORRISPONDENTI / MAXIMUM STRAIGHTNESS DEVIATION, IN %, IN RELATION TO THE CORRESPONDING PRODUCTION DIMENSIONS / MARGE DE TOLÉRANCE DE RECTITUDE, EN POURCENTAGE, PAR RAPPORT AUX DIMENSIONS DE FABRICATION CORRÉPONDANTES / ZULÄSSIGE ABWEICHUNG DER KANTENGERADHEIT IM VERHÄLTNIS ZU DEN ENTSPRECHENDEN HERSTELLMAßEN IN PROZENTEN / DESVIACION MÁXIMA DE RECTITUD, EN TANTO POR CIENTO, EN RELACIÓN CON EL TAMAÑO DE FABRICACIÓN CORRESPONDIENTE.	Squadrato ISO 13006	±0,3 %	±0,8 mm	±0,10 %	ISO 10545-2	
	DEVIAZIONE MASSIMA DI ORTOGONALITÀ, IN PERCENTO, IN RAPPORTO ALLE DIMENSIONI DI FABBRICAZIONE CORRISPONDENTI MAXIMUM RIGHT-ANGLE DEVIATION, IN %, IN RELATION TO THE CORRESPONDING PRODUCTION DIMENSIONS / MARGE DE TOLÉRANCE D'ANGULARITÉ, EN POURCENTAGE, PAR RAPPORT AUX DIMENSIONS DE FABRICATION / HÖHE ABWEICHUNG DER RECHTWINKELIGKEIT IM VERHÄLTNIS ZU DEN ENTSPRECHENDEN HERSTELLMAßEN IN PROZENTEN / DESVIACION MÁXIMA DE LA ORTOGONALIDAD, EN TANTO POR CIENTO, EN RELACIÓN CON EL TAMAÑO DE FABRICACIÓN CORRESPONDIENTE.	Squadrato ISO 13006	±0,3 %	±1,5 mm	±0,20 %	ISO 10545-2	
	PLANARITÀ (CURVATURA DEL CENTRO, DELLO SPIGOLO E SVERGOLAMENTO) / FLATNESS (CURVING IN THE MIDDLE, CORNER AND WARPING) / PLANÉITÉ (COURBURE CENTRALE, DE L'ARÊTE ET GAUCHISSEMENT) / EBENFLÄCHIGKEIT (KRÜMMUNG DER MITTE, DER KANTE UND VERWINDUNG) / PLANITUD (CURVATURA DEL CENTRO, DE LA ARISTA Y ABARQUILLAMIENTO).	Squadrato ISO 13006	±0,4 %	±1,8 mm	±0,20 %	ISO 10545-2	
	QUALITÀ DELLA SUPERFICIE / SURFACE QUALITY / QUALITÉ DE LA SURFACE / QUALITÄT DER OBERFLÄCHE / CALIDAD DE LA SUPERFICIE.				CONFORME/CONFORMING CONFORME/KONFORM CONFORME	ISO 10545-2	
	MASSA D'ACQUA ASSORBITA IN % / % WATER ABSORPTION - MASSE D'EAU ABSORBÉE EN % / WASSERAUFNAHME IN % / MASA DE AGUA ABSORBIDA EN %		E≤0,5 %		valore medio 0,08 %	ISO 10545-3	
	FORZA DI ROTTURA IN N (sp. < 7,5 mm) - BREAKING STRENGTH IN N (thickness < 7,5 mm) / FORCE DE RUPTURE EN N (ép. < 7,5 mm) / BRUCHLAST IN N (Dicke < 7,5 mm) / FUERZA DE ROTURA EN N (gr. < 7,5 mm).		≥ 700		valore medio 1350 N	ISO 10545-4	
	RESISTENZA ALLA FLESSIONE IN N/mm² / N/mm² FLEXURAL STRENGTH TEST / RÉSISTANCE A LA FLEXION EN N/mm² / BIEGESTÄRKE IN N/mm² / RESISTENCIA A LA FLEXION EN N/mm²		> 35 N/mm²		valore medio 52 N/mm²	ISO 10545-4	
	RESISTENZA ALL'ABRASIONE PROFONDA DELLE PIASTRELLE NON SMALTATE / RESISTANCE TO DEEP ABRASION OF UNGLAZED TILES / RÉSISTANCE À L'ABRASION PROFONDE DES CARREAUX NON ÉMAILLÉS / TIEFENABRIEBFESTIGKEIT UNGLASIRTER FLIESEN / RESISTENCIA A LA ABRASION PROFUNDA DE LAS BALDOSAS SIN ESMALTAR.		< 175 mm³		valore medio 140 mm³	ISO 10545-6	
	RESISTENZA AGLI SBALZI TERMICI / THERMAL SHOCKS RESISTANT / RÉSISTANCE AUX VARIATIONS THERMIQUES / TEMPERATURWECHSELBESTÄNDIGKEIT / RESISTENCIA AL CHOQUE TÉRMICO.				METODO DI PROVA DISPONIBILE / AVAILABLE TESTING METHOD / MÉTHODE D'ESSAI DISPONIBLE / VERFÜGBARE PRÜFMETHODE / MÉTODO DE ENSAYO DISPONIBLE	RESISTE - RÉSISTANT RÉSISTE - ERFÜLLT - RESISTE	ISO 10545-9
	RESISTENZA AL GELO / FROST RESISTANCE / RÉSISTANCE AU GEL / FROSTSICHERHEIT / RESISTENCIA A LA HELADA		RICHIESTA - REQUIRED REQUISE - GEFORDERT REQUERIDA			RESISTE - RÉSISTANT RÉSISTE - ERFÜLLT - RESISTE	ISO 10545-12
	RESISTENZA ALLE MACCHIE / RESISTANCE TO STAINING / RÉSISTANCE AUX TACHES / FLECKENABWEISEND / RESISTENCIA A LAS MANCHAS.				METODO DI PROVA DISPONIBILE / AVAILABLE TESTING METHOD / MÉTHODE D'ESSAI DISPONIBLE / VERFÜGBARE PRÜFMETHODE / MÉTODO DE ENSAYO DISPONIBLE	Classe 4	ISO 10545-14
	RILASCIO DI SOSTANZE PERICOLOSE / RELEASE OF HAZARDOUS SUBSTANCES / REJET DE SUBSTANCES DANGEREUSES / FREISETZUNG GEFAHRLICHER STOFFE / LIBERACION DE SUSTANCIAS PELIGROSAS / CADMIO (in mg/dm²) - PLOMBO (in mg/dm²)				VALORE DICHIARATO PER SUPERFICIE GL. CON IMPEGHI SU PIANI DI LAVORO / DECLARED VALUE FOR GL. SURFACES USED ON WORKTOPS / VALEUR DÉCLARÉE POUR SURFACES GL. UTILISÉES SUR PLANS DE TRAVAIL / ANGEBORENER WERT FÜR GL. OBERFLÄCHEN ZUM GEBRAUCH ALS ARBEITSPLÄTZE / VALOR DICHIARATO PARA ARBOZADOS GL. UTILIZADOS PARA SUPERFICIES DE TRABAJO	CONFORME/CONFORMING CONFORME/KONFORM CONFORME	DM-1-2-2007-Reg-CE-1935-2004
	RESISTENZA A BASSE CONCENTRAZIONI DI ACIDI E ALCALI. / RESISTANCE TO LOW CONCENTRATIONS OF ACIDS AND ALKALIS. / WIDERSTAND GEGEN NIEDRIGE KONZENTRATIONEN VON SAUREN UND LAUGEN. / RESISTENCIA A BAJAS CONCENTRACIONES DE ACIDOS Y ALCALIS.		COME DICHIARATO DAL PRODUTTORE SEE MANUFACTURER'S DECLARATION SELON DÉCLARATION DU PRODUCTEUR ENTSPRECHEND DER HERSTELLERANGABEN TAL COMO DECLARA EL FABRICANTE			LA	ISO 10545-13
	RESISTENZA A ALTE CONCENTRAZIONI DI ACIDI ED ALCALI / RESISTANCE TO HIGH CONCENTRATIONS OF ACIDS AND ALKALIS / WIDERSTAND GEGEN STARK KONZENTRIERTE SAUREN UND LAUGEN / RESISTENCIA A ALTAS CONCENTRACIONES DE ACIDOS Y ALCALIS		METODO DI PROVA DISPONIBILE / AVAILABLE TESTING METHOD / MÉTHODE D'ESSAI DISPONIBLE / VERFÜGBARE PRÜFMETHODE / MÉTODO DE ENSAYO DISPONIBLE			HA	
	RESISTENZA AI PRODOTTI CHIMICI DI USO DOMESTICO E AGLI ADDITIVI PER PISCINA / RESISTANCE TO DOMESTIC CHEMICAL PRODUCTS AND ADDITIVES FOR SWIMMING POOLS / RÉSISTANT AUX PRODUITS CHIMIQUES À USAGE DOMESTIQUE ET AUX ADDITIFS POUR PISCINE / WIDERSTAND GEGEN HAUSHALTS-CHEMIKALIEN UND / SCHWIMMBADZUSATZSTOFFEN / RESISTENCIA A PRODUCTOS PARA LIMPIEZA DOMESTICA Y ADITIVOS PARA PISCINAS		MIN B			A	
	COEFFICIENTE D'ATTRITO (SCIVOLOSITÀ) / FRICTION COEFFICIENT (SLIPPERINESS) / COEFFICIENT DE FRICTION (GLISSEMENT) / REIBUNGSKOEFFIZIENT (SCHLUPFRIGKEIT) / COEFFICIENTE DE ANTI DESLIZAMIENTO.		-			> 0,42 wet	ANSI A 326.3
			-			18° ≤ α < 24° classe B	DIN EN 16165 ANNEX A
			-			6° < α ≤ 10° R9	DIN EN 16165 ANNEX B
			-			PTV >36 wet slider 4S	BS EN 16165 ANNEX C

Per un effetto ottimale della posa, florim suggerisce di mantenere 2 mm di fuga per pose monofornate e 3 mm per combinare formati misti / For optimal installation results, florim recommends maintaining a joint of 2 mm 1/12" for single format installations and 3 mm 1/8" to combine mixed formats / Pour réaliser une pose parfaite, florim suggère de maintenir 2 mm de joint pour la pose des monofornats, et 3 mm pour les combinaisons de formats mixtes / Um einen optimalen effekt beim verlegen zu erzielen empfiehlt florim eine 2 mm fuge bei einformatigen verlegungen und 3 mm fuge bei formatkombinationen / Para lograr el efecto óptimo de la posa del producto, florim aconseja 2 mm de junta en aplicaciones monofornato y 3 mm en combinaciones de formatos mixtos.

**schemi di posa** / laying scheme / schéma de pose  
Verlegungsschemen / esquema de colocación

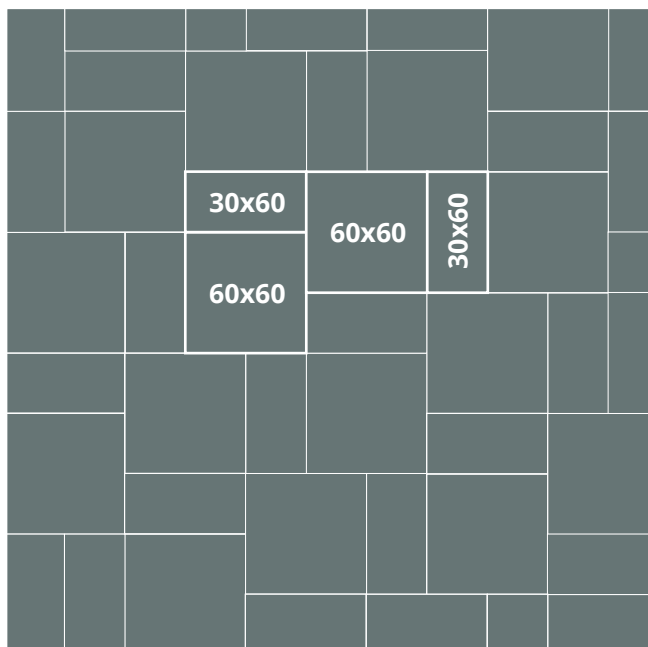

**Mod. A - 2 formati**

**30x60**  $11\frac{3}{4}'' \times 23\frac{5}{8}''$  / 33,33 %

**60x60**  $23\frac{5}{8}'' \times 23\frac{5}{8}''$  / 66,66 %

**INDUSTRIAL**

FLORIM OVERSIZE  
magnUm

<b>CE</b>
<b>FLORIM Ceramiche S.p.A SB</b> Via Canaletto, 24 - 41042 Fiorano Modenese (MO) - Italia 05 <b>FLORIM 001</b>
<b>EN 14411:2012</b> <b>Dry-pressed ceramic tiles, with water absorption</b> <b><math>E_b \leq 0,5 \%</math>, for internal and external walls and floorings</b>

Per informazioni relative ai dati tecnici su marcatura CE vedere il sito [www.florim.com](http://www.florim.com)  
 Please refer to our web site [www.florim.com](http://www.florim.com) for technical information related to CE labeling.  
 Pour tout renseignement sur l'étiquetage technique de la marque CE veuillez consulter le site [www.florim.com](http://www.florim.com)  
 Informationen bezüglich technischer Daten zur Beschriftung CE entnehmen Sie unserer Website [www.florim.com](http://www.florim.com)  
 Para informaciones relativas a las especificaciones técnicas sobre la marca CE, chequear el sitio [www.florim.com](http://www.florim.com)

<b>CE</b>
<b>FLORIM Ceramiche S.p.A SB</b> Via Canaletto, 24 - 41042 Fiorano Modenese (MO) - Italia 09 <b>FLORIM 003</b> Rev.1
<b>EN 14411:2012</b> <b>Dry-pressed ceramic tiles, with water absorption</b> <b><math>E_b \leq 0,5 \%</math>, for internal and external walls and floorings</b>

Per informazioni relative ai dati tecnici su marcatura CE vedere il sito [www.florim.com](http://www.florim.com)  
 Please refer to our web site [www.florim.com](http://www.florim.com) for technical information related to CE labeling.  
 Pour tout renseignement sur l'étiquetage technique de la marque CE veuillez consulter le site [www.florim.com](http://www.florim.com)  
 Informationen bezüglich technischer Daten zur Beschriftung CE entnehmen Sie unserer Website [www.florim.com](http://www.florim.com)  
 Para informaciones relativas a las especificaciones técnicas sobre la marca CE, chequear el sitio [www.florim.com](http://www.florim.com)



	Sistema di gestione della Qualità: <b>Certificato n°, 50 100 1271</b>
	Sistema di gestione dell'Ambiente: <b>Certificato n°, 50 100 100 74</b>
	Sistema di gestione della Salute e Sicurezza dei lavoratori: <b>Certificato n°, 50 100 13825</b>
	Sistema di gestione dell'Energia: <b>Certificato n°, 50 100 13545</b>



GRADO DI VARIAZIONE CROMATICA - DEGREE OF COLOUR CHANGE - DEGRE DE VARIATION CHROMATIQUE - GRAD DER FARBABWEICHUNG - GRADO DE VARIACIÓN CROMÁTICA

<p><b>V1 LOW</b> THE LEAST AMOUNT OF SHADE AND TEXTURE VARIATION ATTAINABLE IN NATURALLY FIRED CLAY PRODUCTS. Prodotto Monocromatico Produit Monochromatique Einfarbiges Produkt Producto Monocromático</p>	<p><b>V2 MODERATE</b> LIGHT TO MODERATE SHADE AND TEXTURE VARIATION WITHIN EACH CARTON. Prodotto con leggera variazione cromatica Produit à légère variation chromatique Produkt mit leichter Farbnuanze Producto con una pequeña variación cromática</p>	<p><b>V3 HIGH</b> HIGH SHADE AND TEXTURE VARIATION WITHIN EACH CARTON. Prodotto con marcata variazione cromatica Produit à variation chromatique accentuée Produkt mit ausgeprägter Farbnuanze Producto con evidente variación cromática</p>	<p><b>V4 RANDOM</b> VERY HIGH SHADE AND TEXTURE VARIATION WITHIN EACH CARTON. Prodotto con forte variazione cromatica Produit à forte variation chromatique Produkt mit starker Farbnuanze Producto con fuerte variación cromática</p>
---	---	--	--

Quanto contenuto nel catalogo è indicativo e non esaustivo riguardo alle grafiche, decori e ai colori riportati./Contents of this catalog is indicative and not exhaustive with regard to graphics, decors and colors shown. /Le contenu du catalogue est indicatif et non exhaustive en ce qui concerne graphiques, décors et couleurs indiquées. /Die Beschreibungen im Katalog sind indikativ und nicht allumfassend in Bezug auf Grafiken, Dekore und Farben. /El contenido de este catálogo es indicativo y no exhaustivo con respecto a gráficas, decoros y colores ilustrados.





**Florim Ceramiche S.p.A. SB**

Via Canaletto, 24 / 41042 Fiorano Modenese (MO) / T. +39 0536 840111 / [florim.com](http://florim.com)